

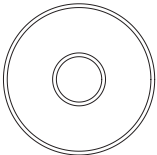

# IN8135

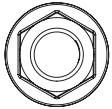
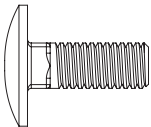
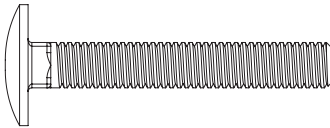
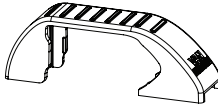
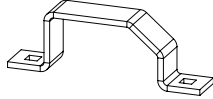
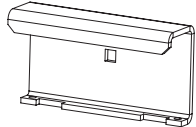
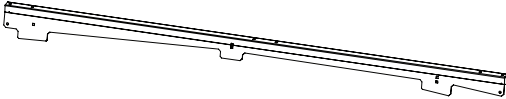
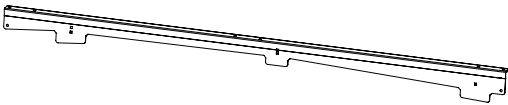

## ULTI Bars - X3

|   |   |  |  |   |   |   |
|---|---|--|--|---|---|---|
| <p><b>FX4013 X6</b><br/>(M6)</p>  | <p><b>FX4016 X18</b><br/>(M6)</p>  | <p><b>FX4042 X12</b><br/>(M6X16)</p>  | <p><b>FX4050 X6</b><br/>(M6X40)</p>  | <p><b>MA6065 X6</b></p>  | <p><b>ME0203 X6</b></p>  | <p><b>ME0814 X6</b></p>  |
| <p><b>ME0727 X1</b></p>           |   | <p><b>ME0728 X1</b></p>              |  |   |   |   |

**TOOLS REQUIRED**



10MM X 1





EN - SAFETY AND PRODUCT INFORMATION  
 DE - SICHERHEITS- UND PRODUKTINFORMATIONEN  
 FR - INFORMATIONS DE SÉCURITÉ ET DU PRODUIT  
 NL - VEILIGHEIDS- EN PRODUCTINFORMATIE  
 ES - INFORMACIÓN DE SEGURIDAD Y DEL PRODUCTO  
 IT - INFORMAZIONI SULLA SICUREZZA E SUL PRODOTTO

SV - SÄKERHETS- OCH PRODUKTINFORMATION  
 DA - SIKKERHEDS- OG PRODUKTINFORMATION  
 NO - SIKKERHETS- OG PRODUKTINFORMASJON  
 PL - INFORMACJE O BEZPIECZENSTWIE I PRODUKCIE  
 CS - INFORMACE O BEZPEČNOSTI A PRODUKTU



**Customercare@van-guard.co.uk**  
**UK +44 (0) 1392 368 351**



**MA6167**

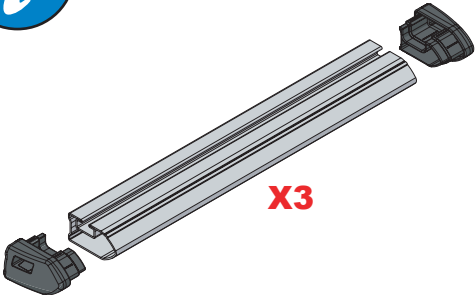

**X3**

**MA6166**

**ULTI Bar Trade**  
(Steel)

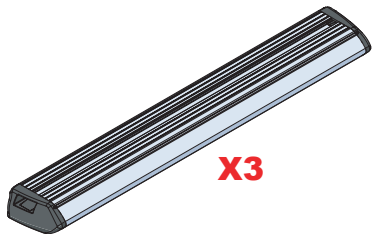

**X3**

**ULTI Bar+**  
(Aluminium)

**1**

The following pages (2, 3 & 4) are for vehicles with the roof rail shown in FIG.1 if your vehicle has the rail shown in FIG.2 please refer to pages 5, 6 & 7. Please note that although the photos in this instruction show the old style roof bar the principle of fitting is the same.

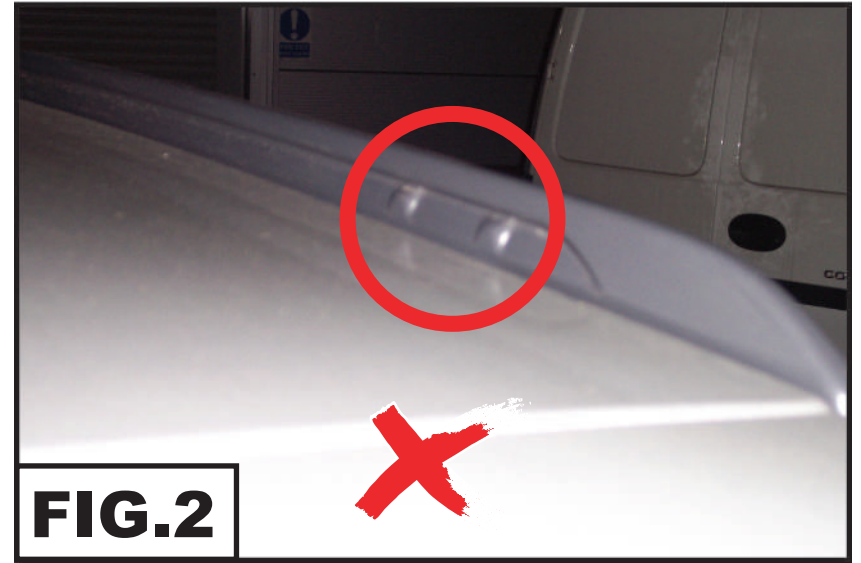
**2**

The side rails are handed to suit both sides of the vehicle.

ILLUSTRATION SHOWS THE RIGHT SIDE RAIL

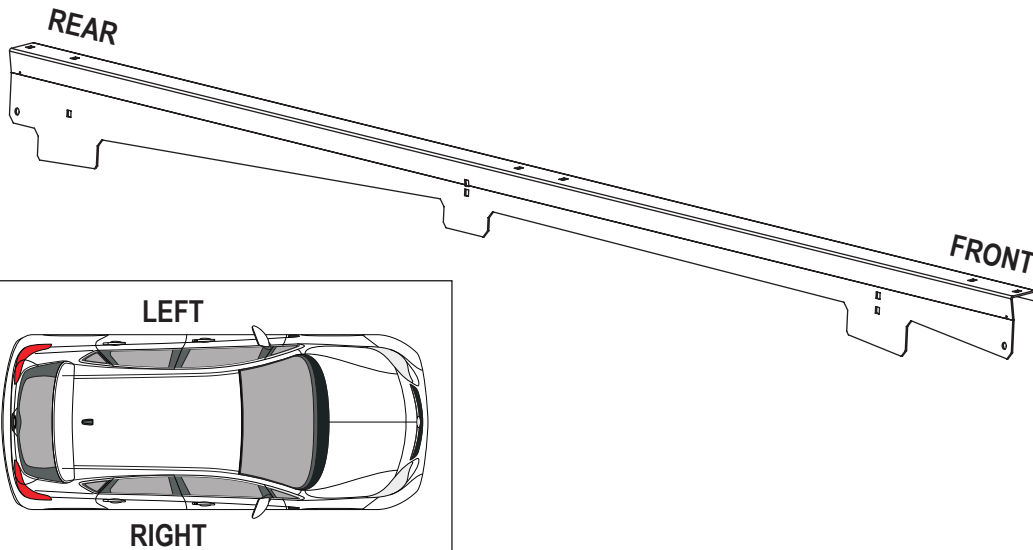
**3**

Position the side rails on the **inside** of the vehicle rail and measure 225mm from closed tailgate door to the centre of the rear fixing hole. Once the side rail is in position carefully push it down into the gap between the factory fitted side rail and the roof to allow correct fitting of the clamps in step 4.

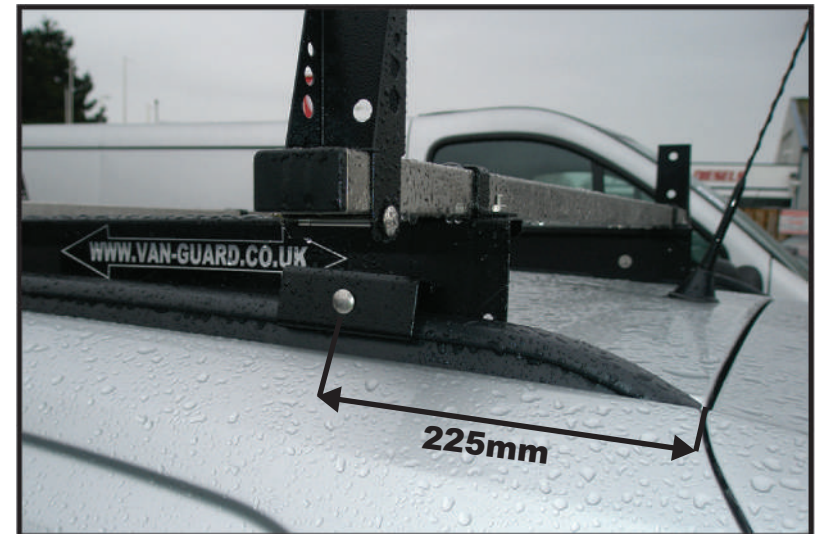

**4**

Insert fixing brackets into the roof rail channel and loosely secure the side rails onto the **inside** of the vehicle rail as shown below using M6x40 coach bolts, M6 washers & M6 serrated nuts. Ensure that the top hat flange is facing inwards.

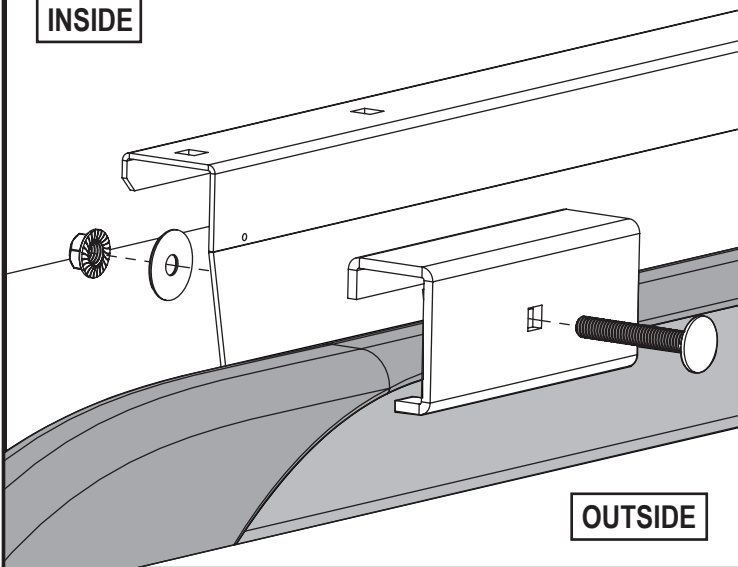
**INSIDE****OUTSIDE****5**

Place roof bars onto the side rails with the t-slot facing upwards, secure using top hat brackets, M6x16 coach bolts & M6 serrated nuts.

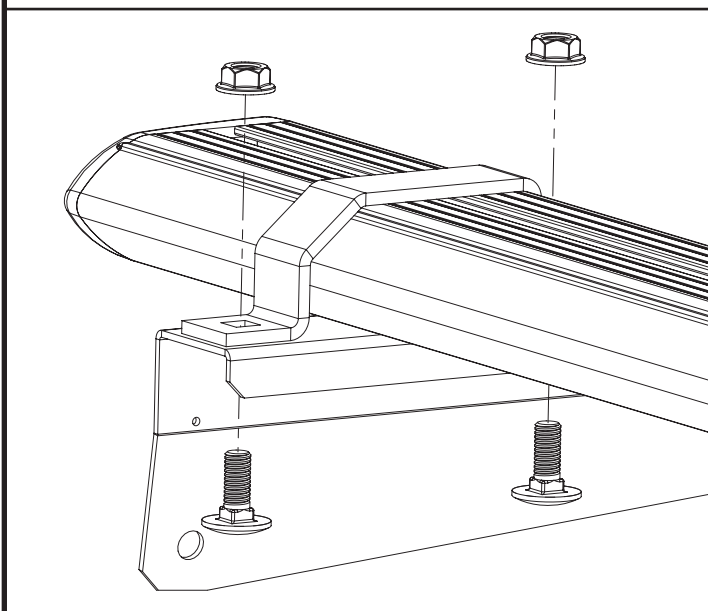
**6**

Flex the top hat covers over the top hat brackets into position as shown below. Ensure that the covers click into the front and rear of the top hat brackets.

1.

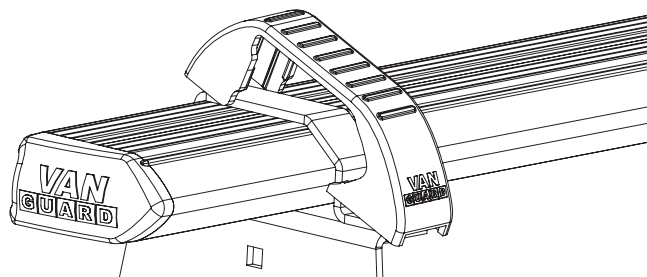

2.

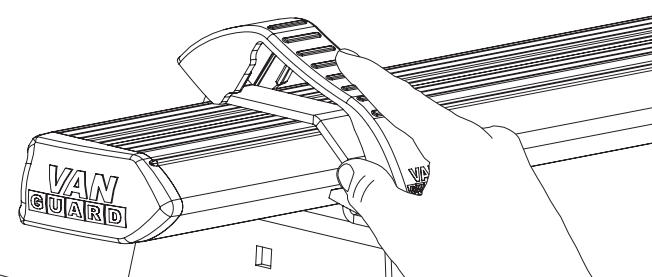

3.

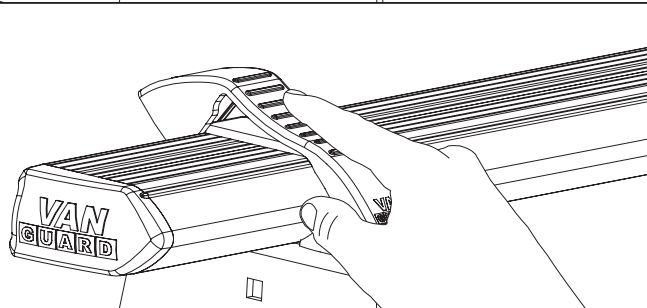

4.

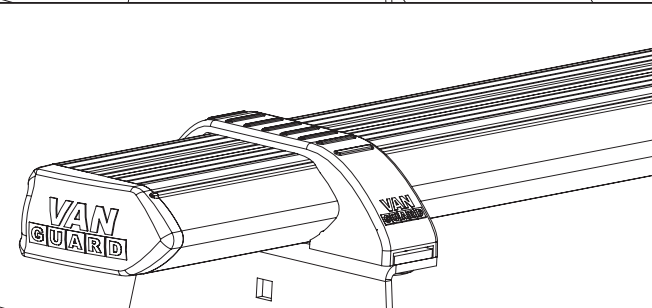

7

Once in position tighten all fixings to 11Nm.  
Periodically check all fixings.



**TIGHTEN  
TO  
11Nm**

**NOTES:**

Please check that the vehicle manufacturers load bearing capacity for the roof is not exceeded. (Refer to the vehicle handbook)  
Periodically check all fixings.  
Retain these instructions for future reference.



1

The following pages (5, 6 & 7) are for vehicles with the roof rail shown in FIG.2 if your vehicle has the rail shown in FIG.1 please refer to pages 2, 3 & 4. Please note that although the photos in this instruction show the old style roof bar the principle of fitting is the same.

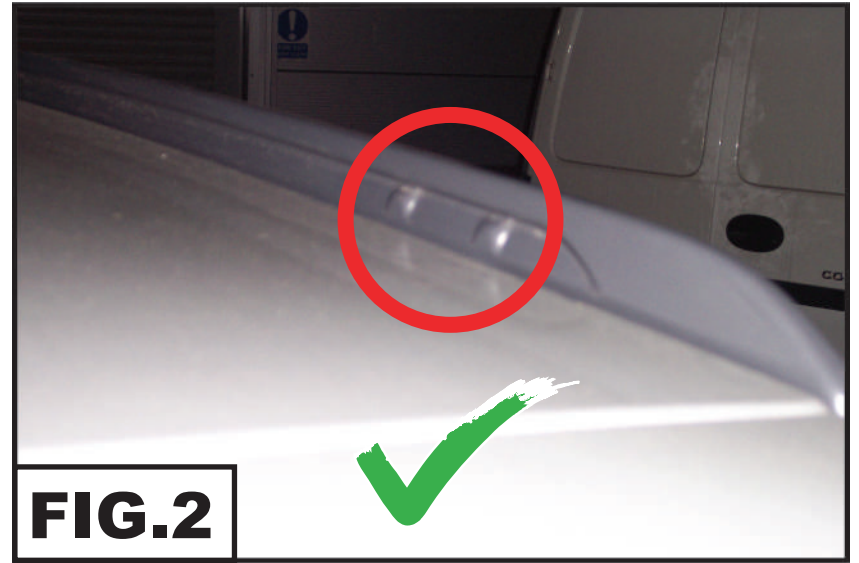

2

The side rails are handed to suit both sides of the vehicle.

ILLUSTRATION SHOWS THE RIGHT SIDE RAIL

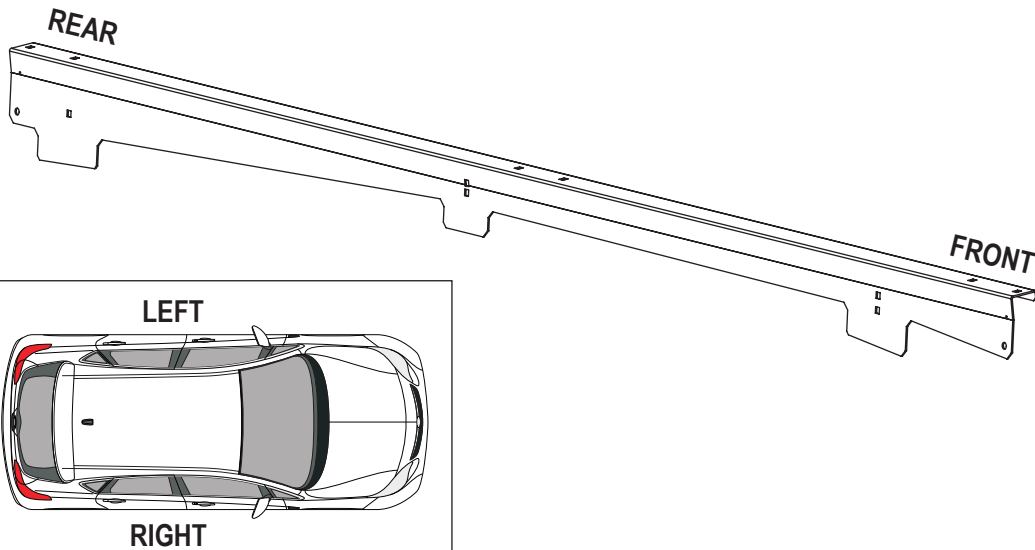

3

Position the side rails on the **outside** of the vehicle rail and measure 210mm from closed tailgate door to the centre of the rear fixing hole. Once the side rail is in position carefully push it down into the gap between the factory fitted side rail and the roof to allow correct fitting of the clamps in step 4.

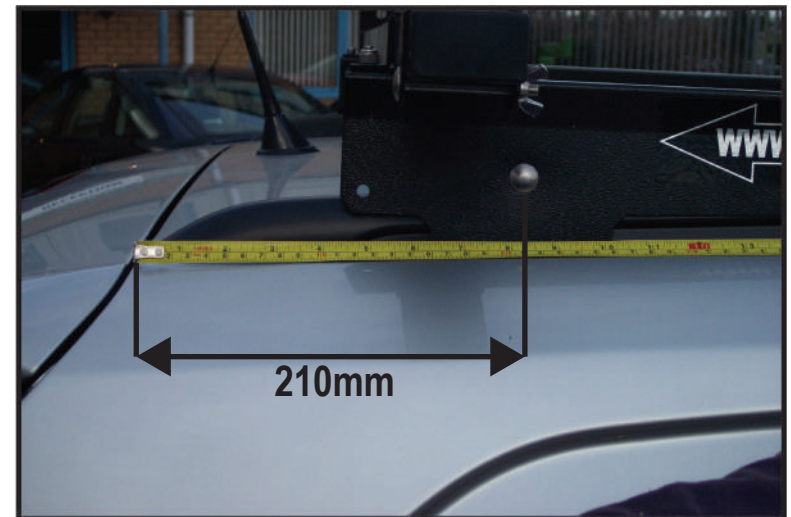

4

Insert fixing brackets into the roof rail channel and loosely secure the side rails onto the **outside** of the vehicle rail as shown below using M6x40 coach bolts, M6 washers & M6 serrated nuts. Ensure that the top hat flange is facing inwards.

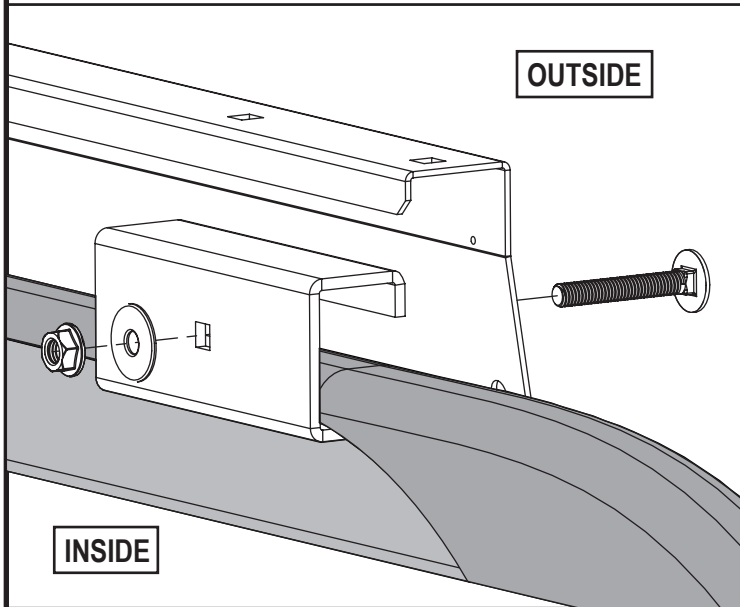

5

Place roof bars onto the side rails with the t-slot facing upwards, secure using top hat brackets, M6x16 coach bolts & M6 serrated nuts.

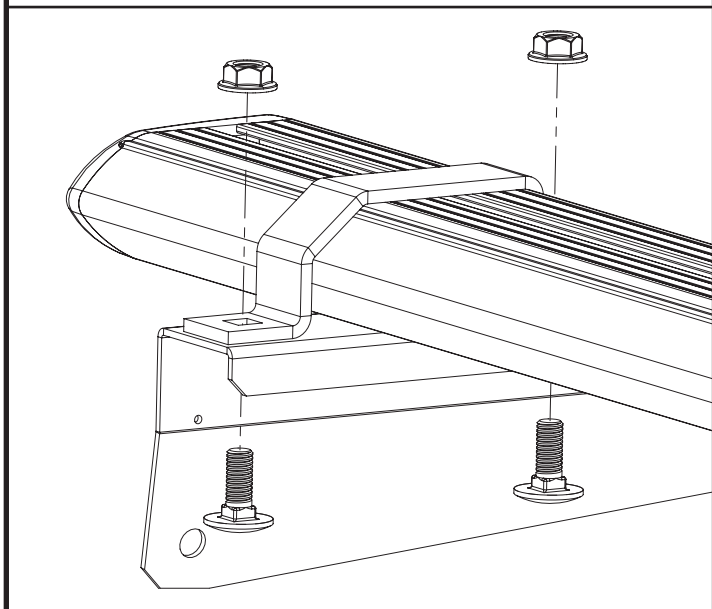

6

Flex the top hat covers over the top hat brackets into position as shown below. Ensure that the covers click into the front and rear of the top hat brackets.

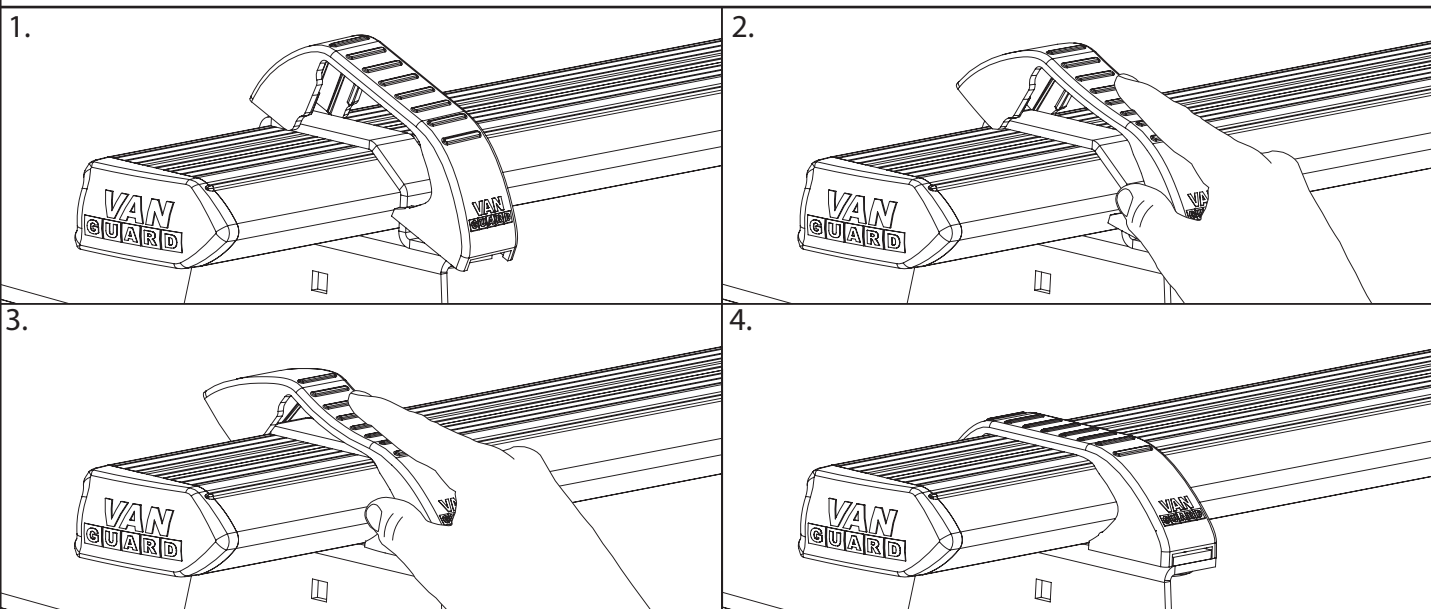

7

Once in position tighten all fixings to 11Nm.  
Periodically check all fixings.



**TIGHTEN  
TO  
11Nm**

**NOTES:**

Please check that the vehicle manufacturers load bearing capacity for the roof is not exceeded. (Refer to the vehicle handbook)  
Periodically check all fixings.  
Retain these instructions for future reference.



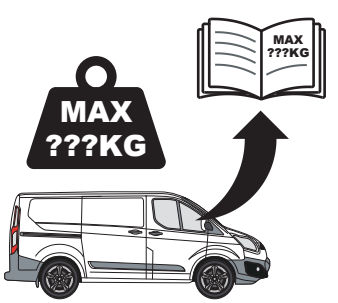

**ULTI Bar Trade**  
(Steel)

**ULTI Bar+**  
(Aluminium)

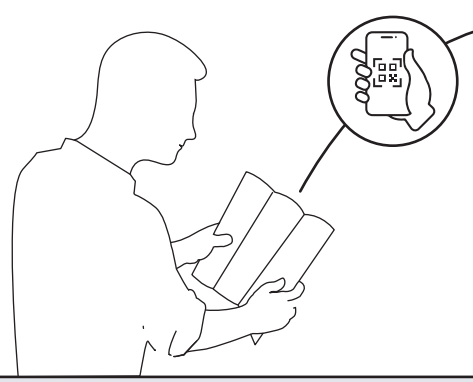

**EN** - SAFETY AND PRODUCT INFORMATION  
**DE** - SICHERHEITS- UND PRODUKTINFORMATIONEN  
**FR** - INFORMATIONS DE SÉCURITÉ ET DU PRODUIT  
**NL** - VEILIGHEIDS- EN PRODUCTINFORMATIE  
**ES** - INFORMACIÓN DE SEGURIDAD Y DEL PRODUCTO  
**IT** - INFORMAZIONI SULLA SICUREZZA E SUL PRODOTTO

**SV** - SÄKERHETS- OCH PRODUKTINFORMATION  
**DA** - SIKKERHEDS- OG PRODUKTINFORMATION  
**NO** - SIKKERHETS- OG PRODUKTINFORMASJON  
**PL** - INFORMACJE O BEZPIECZENSTWIE I PRODUKCIE  
**CS** - INFORMACE O BEZPEČNOSTI A PRODUKTU