

**IN9220**

**Loom Guard - Cab Doors**

**THANK YOU FOR PURCHASING A VAN GUARD LOOM GUARD**

**SUITS THE FOLLOWING MODELS**

**Vehicle:**  
Ford Transit 2014 on

**Door:**  
Cab - Driver's / Passenger's

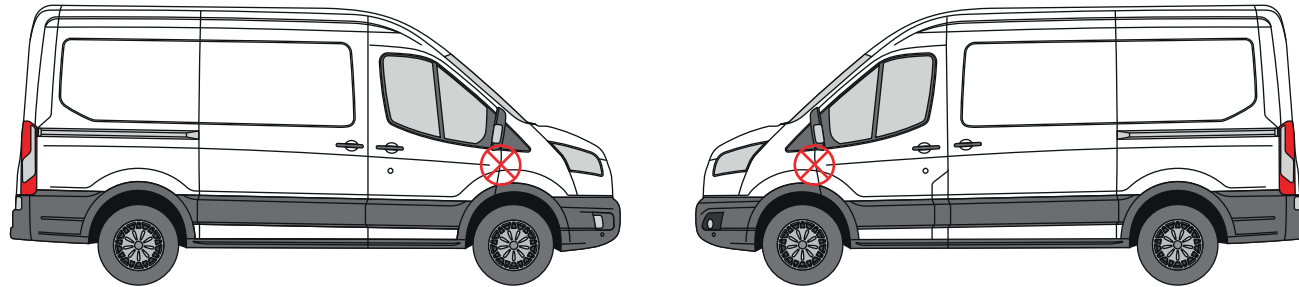

⊗ Indicates approximate placement of guard



**CAUTION**

**PLEASE TAKE THE TIME TO READ THROUGH THE IMPORTANT INFORMATION BELOW BEFORE PROCEEDING TO FIT THIS PRODUCT**



**FAILURE TO TAKE NOTICE OF THE FOLLOWING INFORMATION MAY RESULT IN DAMAGE TO THE VEHICLE.**



**Important:** Follow the instructions and all measurements carefully. Double check measurements before making any cuts. Drawings are for guidance only. Every effort has been made to ensure the accuracy of the instructions provided however Van Guard Accessories Ltd accepts no liability for any inaccuracies of either the drawings provided or vehicle variations. All bare metal should be treated with a manufacturer approved anti-corrosion compound and no liability is accepted for any incorrect installation or corrosion to body panels or within cavities. It is the sole responsibility of the installer to ensure the suitability of both the vehicle and of the supplied parts before installation is started. No liability is accepted for the fitting of the products.

This FITTING INSTRUCTION is the property of VAN GUARD ACCESSORIES LTD. and must not be used for manufacturing purposes, copied nor communicated in any way to third parties without written permission from VAN GUARD ACCESSORIES LTD.  
IN9220\_B

Van Guard Accessories Ltd  
Fair Oak Close, Exeter Airport Business Park,  
Exeter, Devon, EX5 2UL  
[www.van-guard.co.uk](http://www.van-guard.co.uk)

# SUPPLIED COMPONENTS

**AS3272 X1**  
(DRIVER'S DOOR LOOM GUARD)

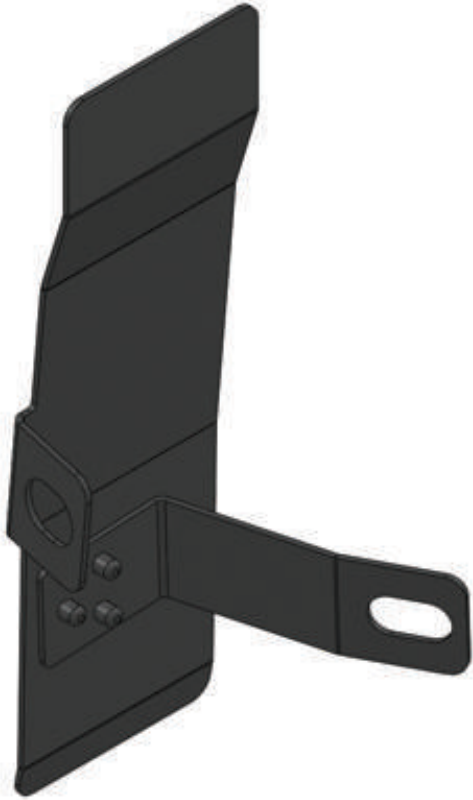

**AS3273 X1**  
(PASSENGER'S DOOR LOOM GUARD)



Wear the appropriate protective equipment (safety glasses & gloves) while fitting this product.



Dispose of packaging materials responsibly - Do not dispose until you have checked all parts and fixings are present.

## FITTED IMAGE



## 1. UNDO BOLT & TORX SCREW

Open the cab door to reveal bolt and torx screw, these will need removing. The wiring loom will need pulling up to allow easy access to the bolt. Unscrew bolt from behind wiring loom and unscrew the torx screw. **Retain both for re-fitting.**

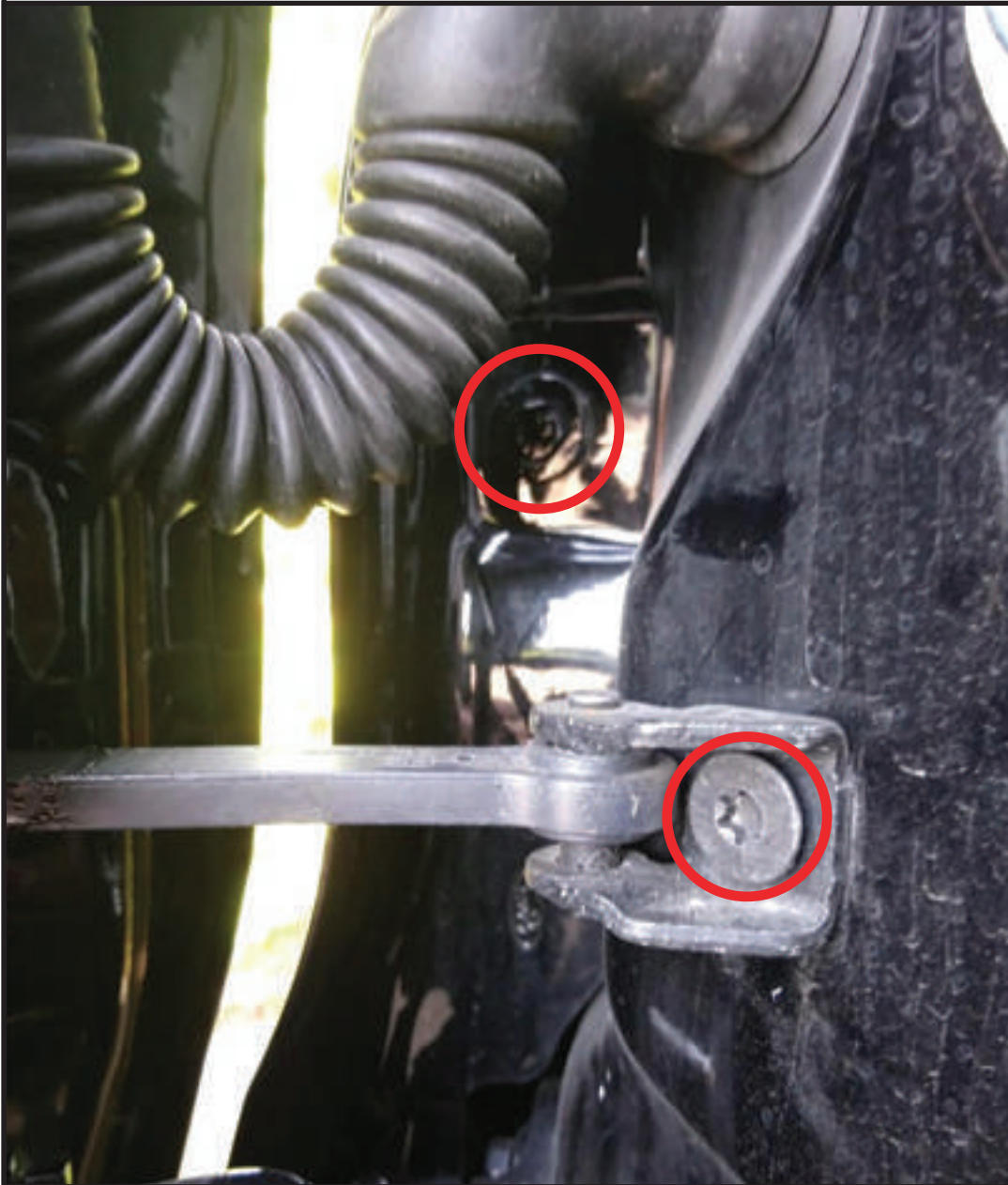

## 2. FITTING THE LOOM GUARD

Hold the loom guard in place lining up the holes with the removed bolt and torx screw and re-attach.

