

IN9307

Internal Shield - Twin Rear Door

THANK YOU FOR PURCHASING A VAN GUARD INTERNAL SHIELD

SUITS THE FOLLOWING MODELS

Vehicle:
Mercedes Sprinter 2018 on

Door:
Rear - Twin

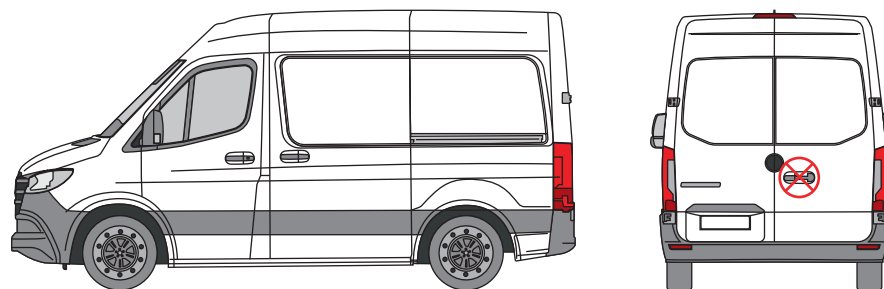

⊗ Indicates approximate placement of shield



CAUTION

PLEASE TAKE THE TIME TO READ THROUGH THE IMPORTANT INFORMATION BELOW BEFORE PROCEEDING TO FIT THIS PRODUCT



FAILURE TO TAKE NOTICE OF THE FOLLOWING INFORMATION MAY RESULT IN DAMAGE TO THE VEHICLE.



Important: Follow the instructions and all measurements carefully. Double check measurements before making any cuts. Drawings are for guidance only. Every effort has been made to ensure the accuracy of the instructions provided however Van Guard Accessories Ltd accepts no liability for any inaccuracies of either the drawings provided or vehicle variations. All bare metal should be treated with a manufacturer approved anti-corrosion compound and no liability is accepted for any incorrect installation or corrosion to body panels or within cavities. It is the sole responsibility of the installer to ensure the suitability of both the vehicle and of the supplied parts before installation is started. No liability is accepted for the fitting of the products.

This FITTING INSTRUCTION is the property of VAN GUARD ACCESSORIES LTD. and must not be used for manufacturing purposes, copied nor communicated in any way to third parties without written permission from VAN GUARD ACCESSORIES LTD.
IN9307_A

Van Guard Accessories Ltd
Fair Oak Close, Exeter Airport Business Park,
Exeter, Devon, EX5 2UL
www.van-guard.co.uk

SUPPLIED COMPONENTS

ME3374 X1
(SHIELD)

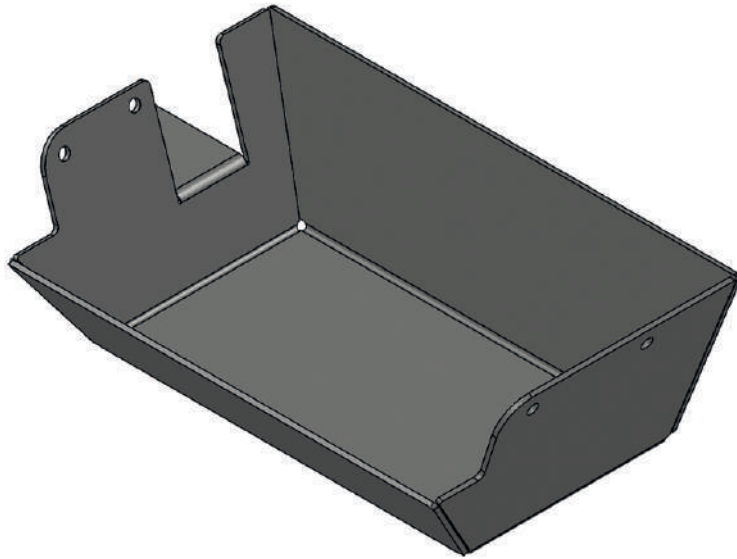

FX4153 X4
(DOME HEAD STEEL RIVET - 4.8 X 18)

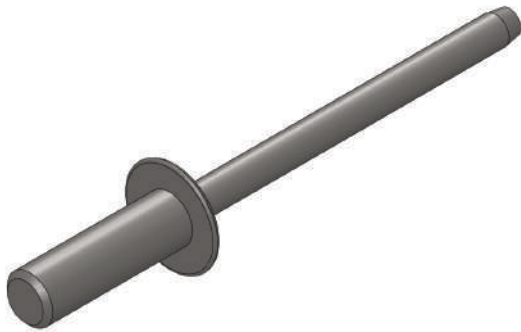

FITTED IMAGE



Wear the appropriate protective equipment (safety glasses & gloves) while fitting this product.



Dispose of packaging materials responsibly - Do not dispose until you have checked all parts and fixings are present.

1.1. REMOVAL OF DOOR CARD

Take off the inner door card by firstly removing the 9 plastic clips securing the card.



1.2. REMOVAL OF DOOR CARD

Carefully rotate the door card so you can pull it over the inner door handle. **Note:** The inner door handle surround does not unclip in the same way as the 2006-2017 model).



2.1. REMOVAL OF INTERNAL RELEASE HANDLE

Remove the inner door handle assembly as a complete unit. There is a hook/tab in the top of the assembly which needs to be unclipped to allow the top to slide across from right to left.



2.2. REMOVAL OF INTERNAL RELEASE HANDLE

To allow the assembly to be fully removed, press inward the tab on the underside of the assembly. This is shown in Fig. 2 outside of the door for easy identification



2.3. REMOVAL OF INTERNAL RELEASE HANDLE

Once the tab is depressed the whole assembly can slide from right to left and be removed from the door. There is no need to disconnect any cables.

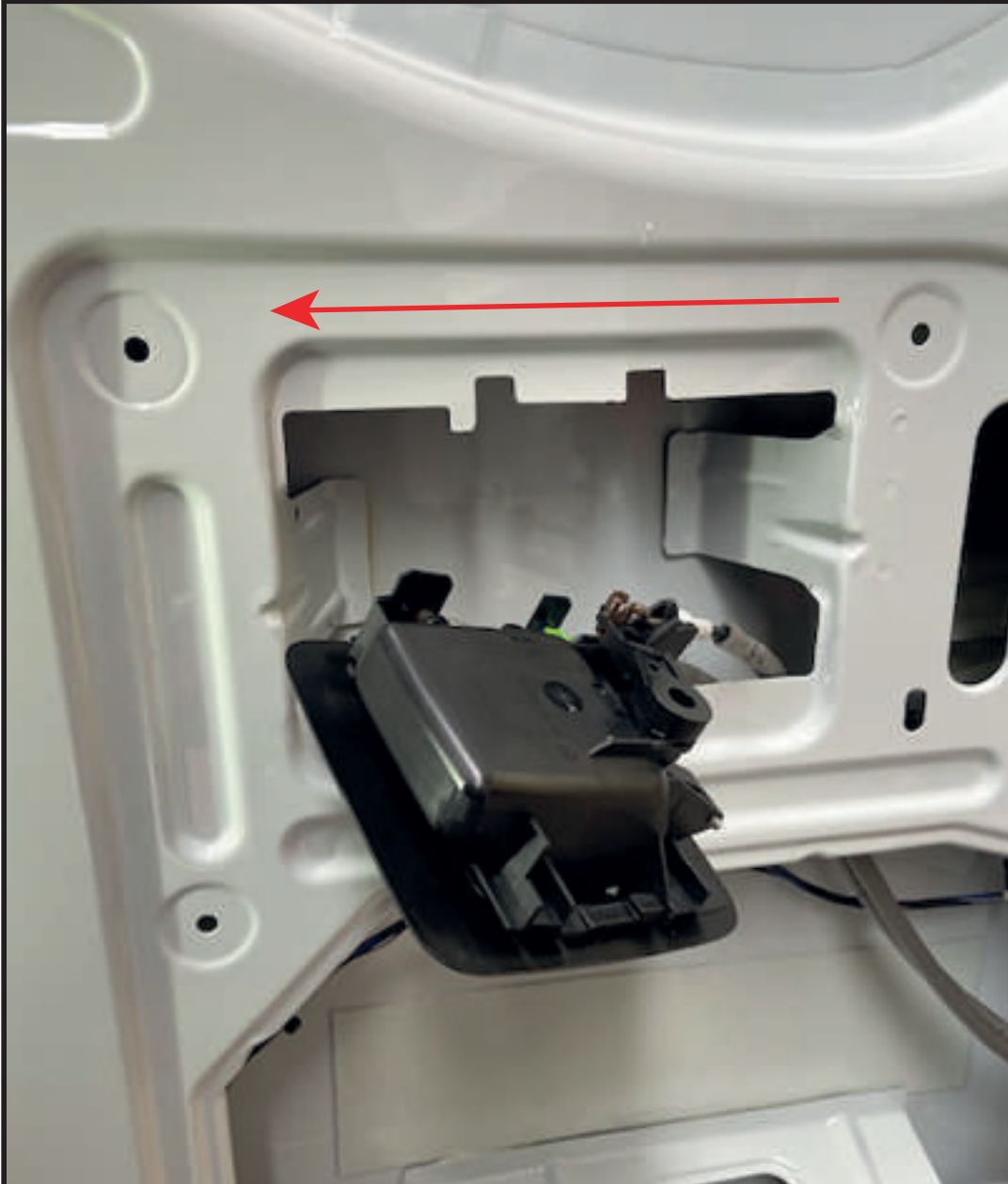

3. POSITIONING THE SHIELD

Insert the shield into the door aperture behind the handle assembly. Hook the cable protection tab in first (FIG.1), then the bottom of the shield (FIG.2) and press up into position (FIG.3).



4.1. FIXING THE SHIELD

Ensuring the cables are not trapped, position the shield in the aperture and carefully drill 5mm holes through each hole (four positions in total).



4.2. FIXING THE SHIELD

Secure the shield into place using the supplied rivets.

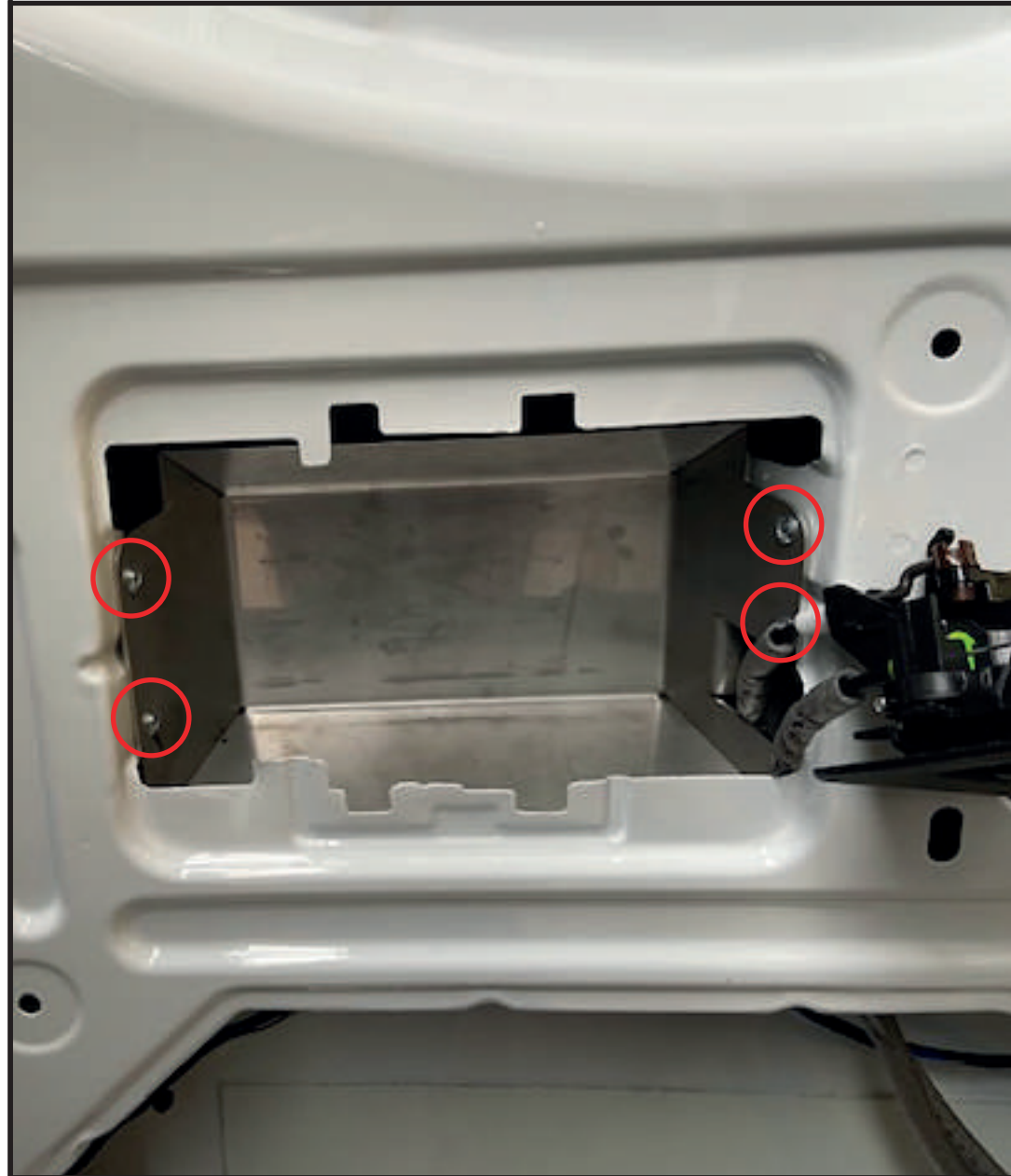

5. REFITTING THE DOOR PANEL

With the shield fixed into position, refit the door handle assembly by positioning it back in its aperture, ensuring it is hooked over the door skin correctly, slide from left to right to locate it into place. Then refit the door card over the handle assembly and fix into place using the plastic clips.

