

IN8324

ULTI Rack+

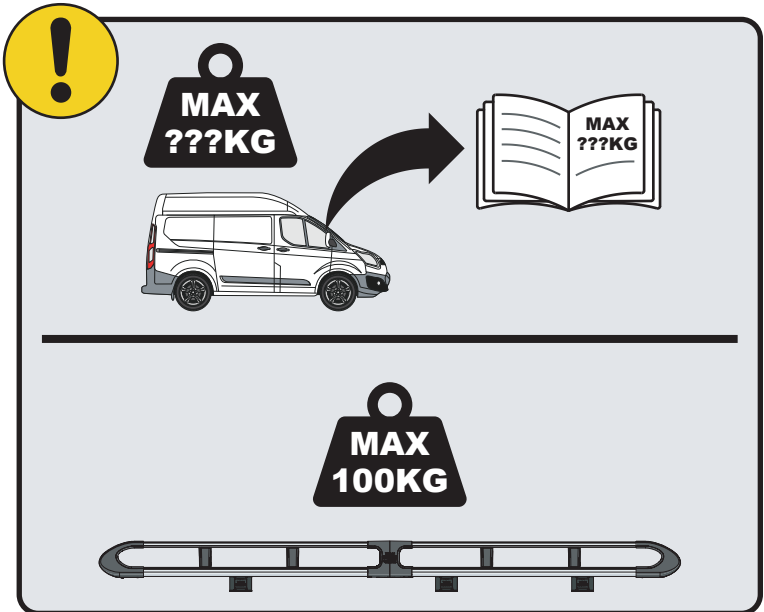

 Customercare@van-guard.co.uk
UK +44 (0) 1392 368 351

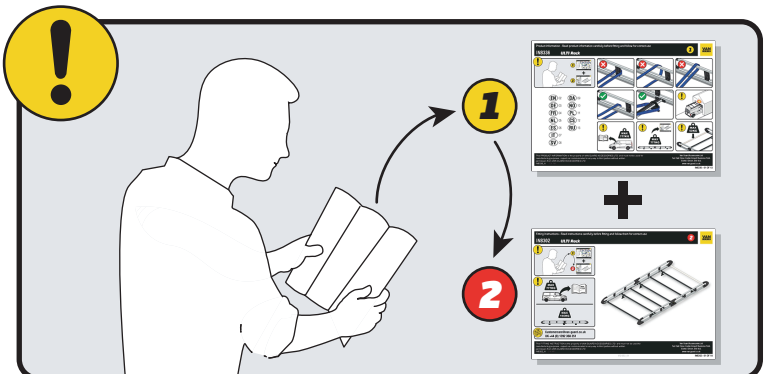

This FITTING INSTRUCTION is the property of VAN GUARD ACCESSORIES LTD. and must not be used for manufacturing purposes, copied nor communicated in any way to third parties without written permission from VAN GUARD ACCESSORIES LTD.
IN8324_A (CN:NR)

Van Guard Accessories Ltd
Fair Oak Close, Exeter Airport Business Park,
Exeter, Devon, EX5 2UL
www.van-guard.co.uk

THIS INSTRUCTION COVERS THE FOLLOWING MODELS - CHECK YOU ARE FITTING THE CORRECT MODEL BEFORE PROCEEDING

VGUR-253

Ford Transit Custom: 2012-2023
L2H2 (LWB)
Twin Rear Doors

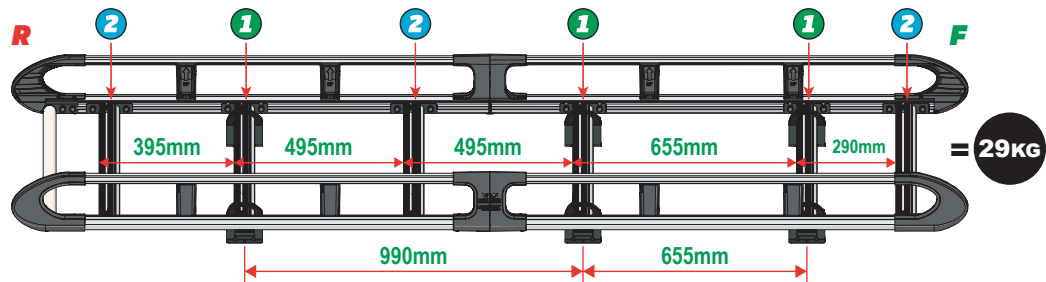
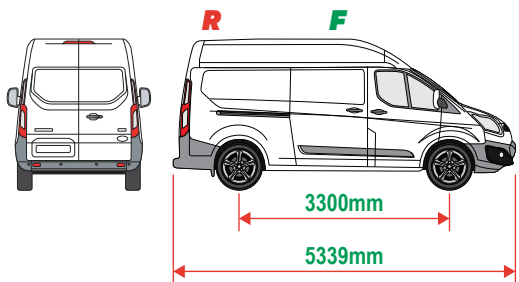

SUPPLIED COMPONENTS - CHECK ALL PARTS ARE PRESENT AND CORRECT BEFORE PROCEEDING (1 OF 2)

TOOLS REQUIRED

10MM X1



13MM X1



Ø6MM X1



10MM LONG HANDLED SOCKET X1

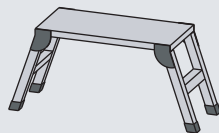
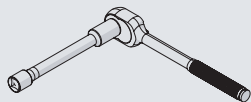

AS3537 X2
(2600 / A)

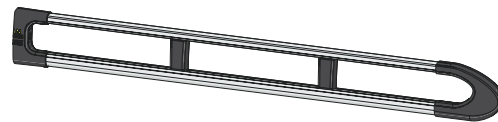

MA6118 X12



FX4241 X28



ME1622 X3

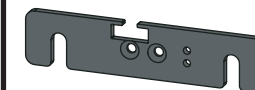

AS3536 X2
(2600 / B)

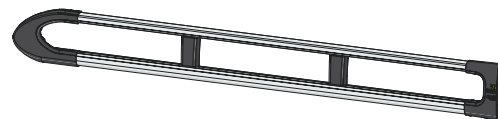

FX4008 X1



MA6145 X1

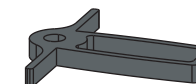

ME1623 X3

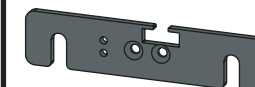

ME1626 X6
(1264mm)

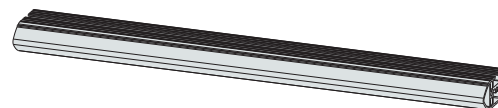

FX4001 X2
(M8X40)

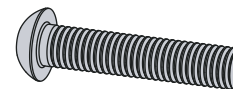

FX4235 X24
(M5X25)



ME0203 X6

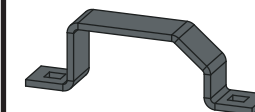

AS3158 X1
(1250mm)

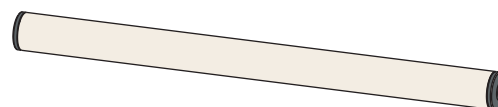

MA6007 X4



FX4248 X1
(T25)

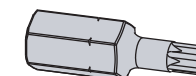

MA6065 X6

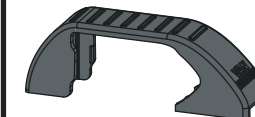

AS3590 X1

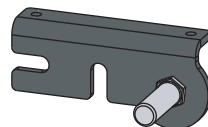

MA6093 X12

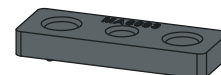

FX4239 X28
(M8X20)

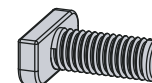

ME1620 X3

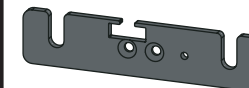

FX4016 X18
(M6)



AS3591 X1

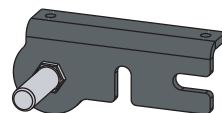

ME0316 X12

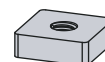

FX4240 X28
(M8)



ME1621 X3

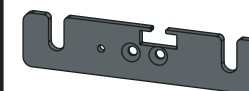

FX4042 X12
(M6X16)

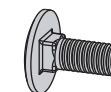

SUPPLIED COMPONENTS - CHECK ALL PARTS ARE PRESENT AND CORRECT BEFORE PROCEEDING (2 OF 2)

ME0776 X2

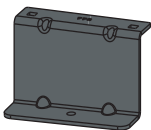

MA6018 X6

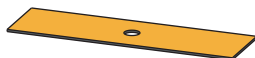

ME0777 X2

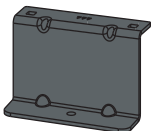

ME0778 X2

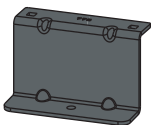

FX4013 X6
(M6)

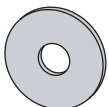

FX4014 X6



FX4026 X6
(M6X20)

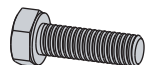

01

1L



X3

1R

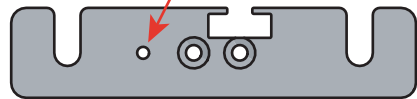

X3



2L



X3

2R



X3

02

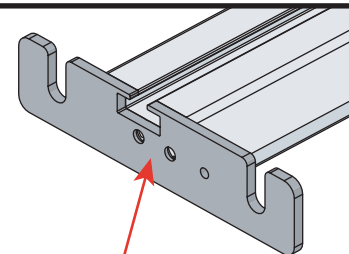
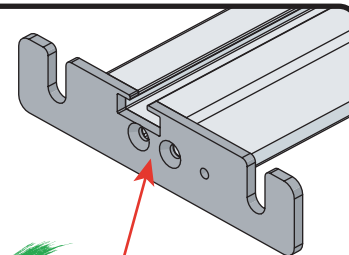

01

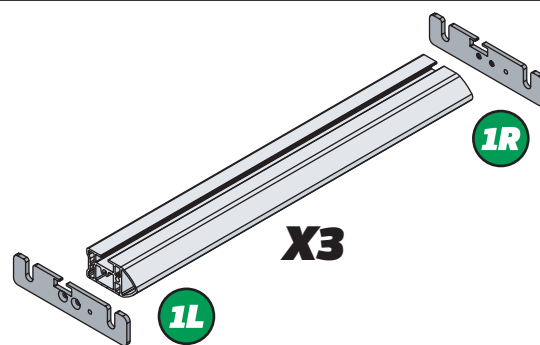

1L

1R

X3

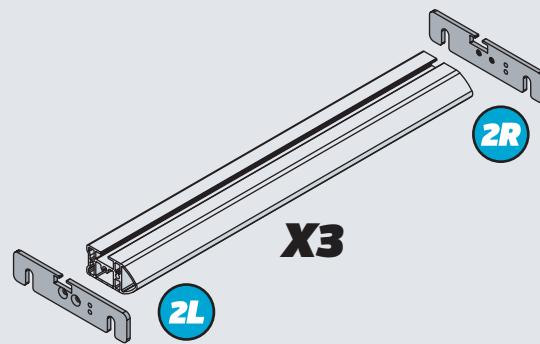

2L

2R

X3

03

01

FX4248



+

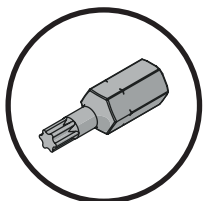

02

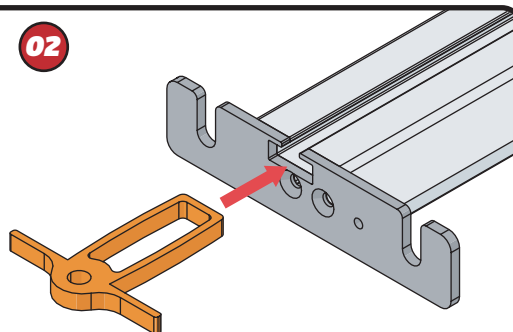

04

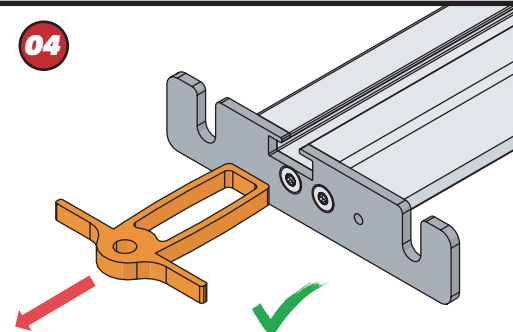

04



1

X3

2

X3

03

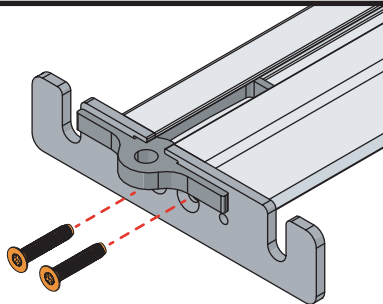

11Nm

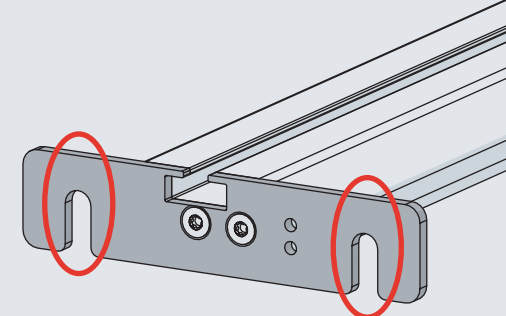
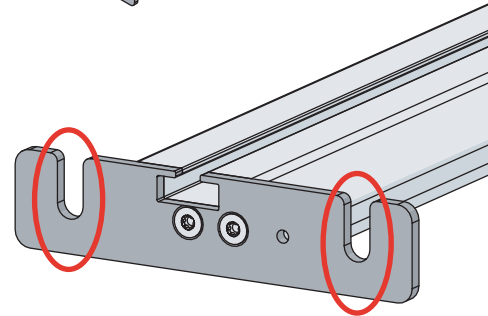

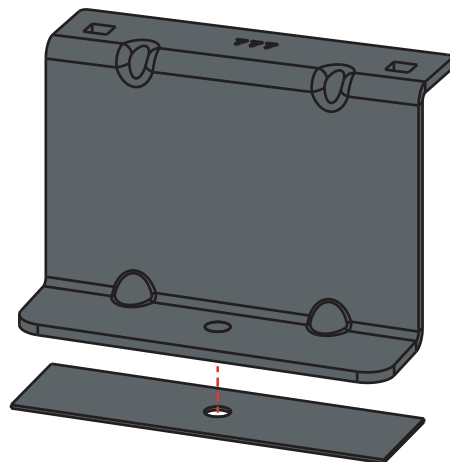
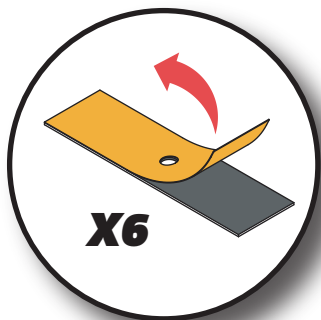
05

EN - STICK GASKETS TO ALL BRACKETS
 DE - KLEBEN SIE DIE DICHTUNG AN ALLEN HALTERUNGEN
 FR - COLLER LES JOINTS SUR TOUS LES SUPPORTS
 NL - PLAK PAKKING OP ALLE BEUGELS
 ES - PEGAR LAS JUNTAS A TODOS LOS SOPORTES
 IT - ADESIVI GUARNIZIONI A TUTTE LE STAFFE

SV - FÄST TÄCKNINGAR PÅ ALLA FÄSTEN
 DA - SÆT PAKNINGER TIL ALLE BESLAG
 NO - PLAST PAKNINGER TIL ALLE BRAKERER
 PL - NAKLEJ USZCZELKI DO WSZYSTKICH WSPORNIKÓW
 CS - PŘILEPTE TĚSNĚNÍ NA VŠECHNY DRŽÁKY

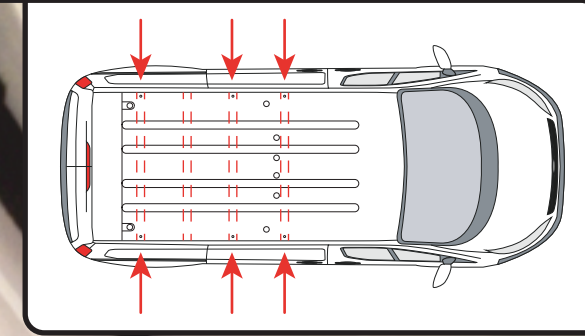
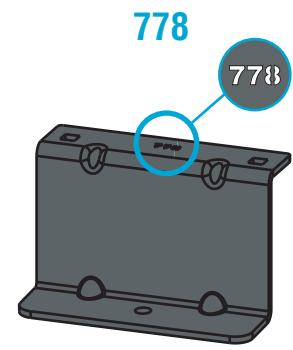
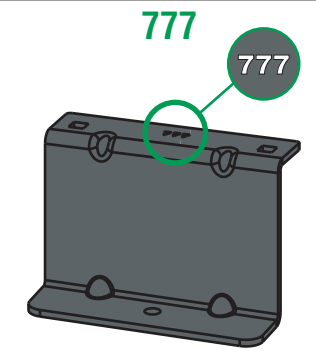
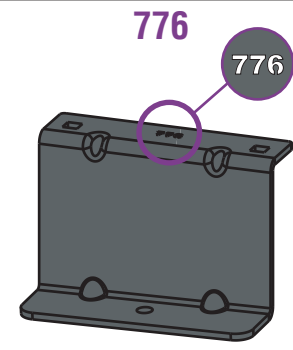
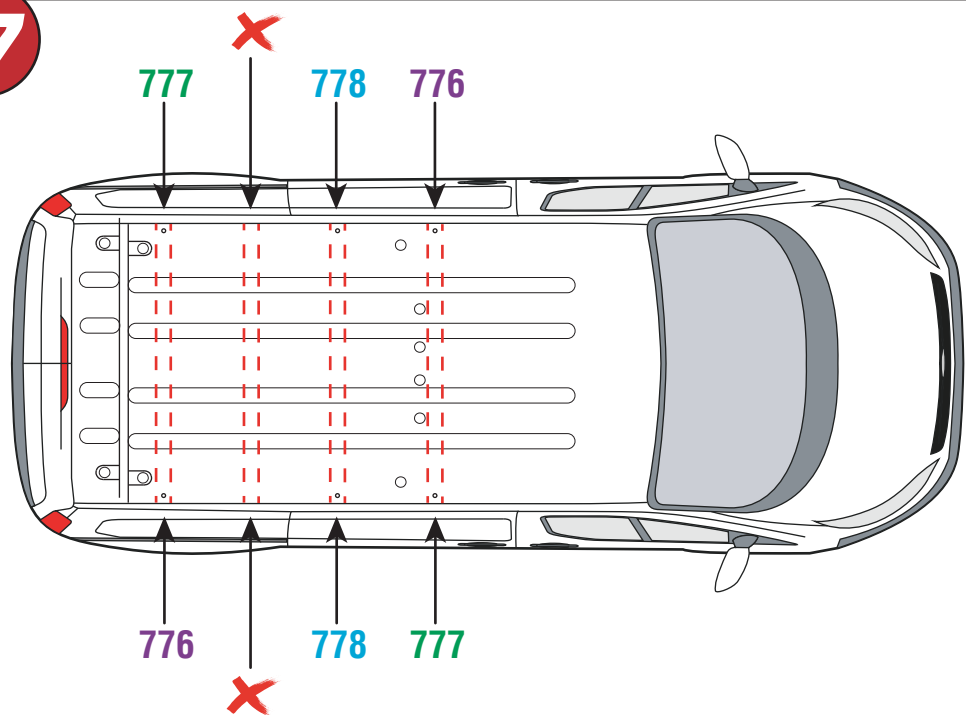
06**07**

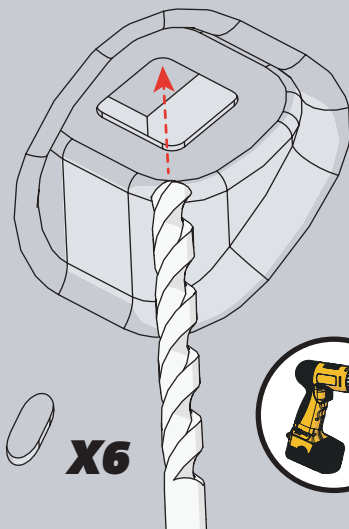
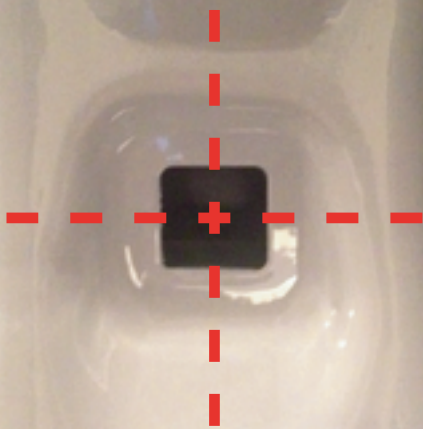
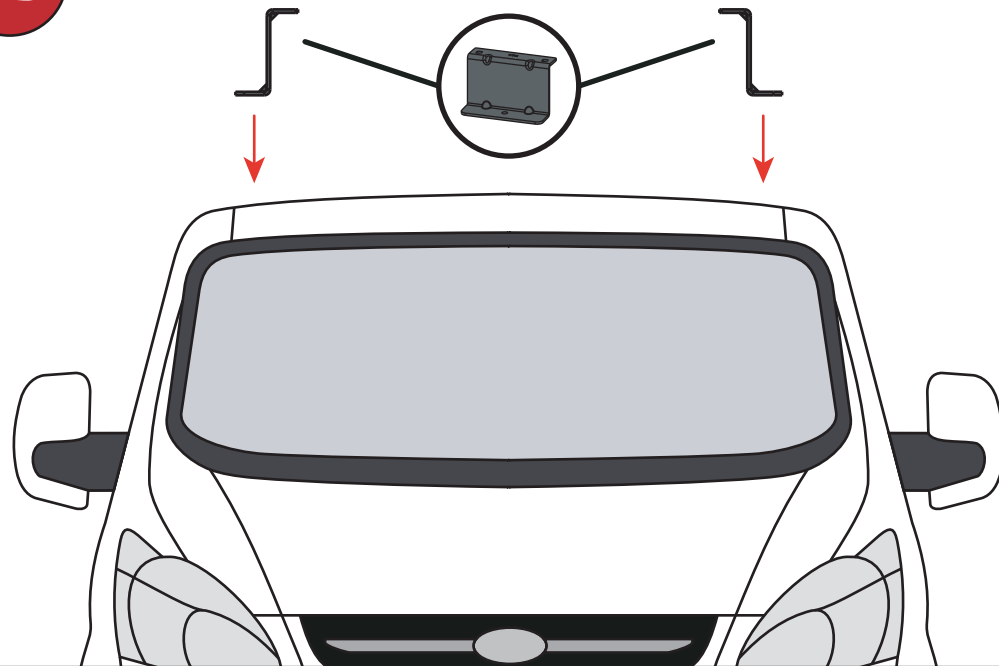
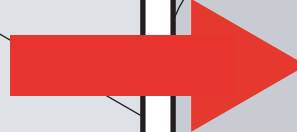
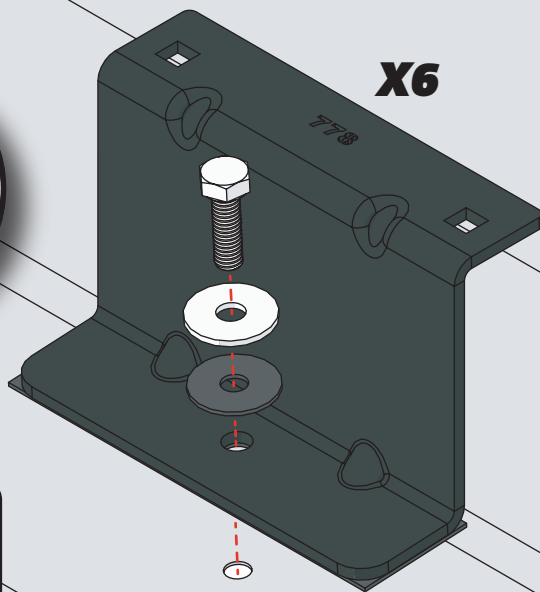
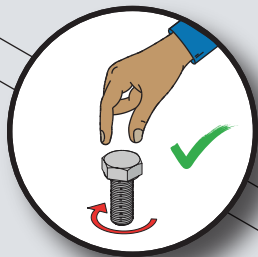
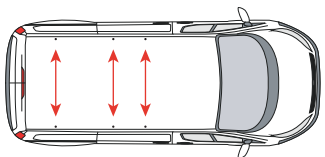
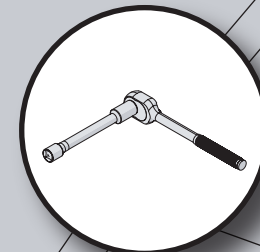
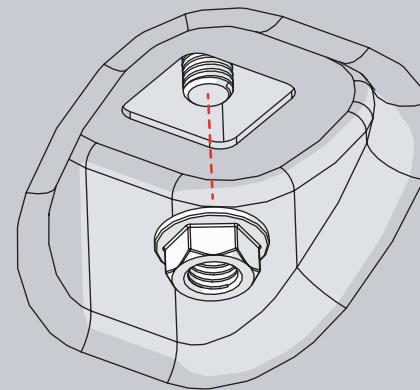
08**Ø6MM****09****10****11**

EN - USE A LONG HANDLED SOCKET
DE - VERWENDEN SIE LANGGRIFFIGE STECKDOSE
FR - UTILISER UNE DOUILLE À LONG MANCHE
NL - GEBRUIK STOPCONTACT MET LANGE HANDGRIEP
ES - UTILICE UN VASO DE MANGO LARGO
IT - UTILIZZARE PRESA A MANICO LUNGO

SV - ANVÄND LÅNGT HÅNDTAGET UTTAG
DA - BRUG LANGHÅNDTAGET STIKNING
NO - BRUK STØTTE MED LANGT HÅNDTAK
PL - UŻYWAJ GNIAZDA Z DŁUGIM UCHWYTEM
CS - POUŽÍVEJTE ZÁSUVKU S DLOUHÝM RUČENÍM

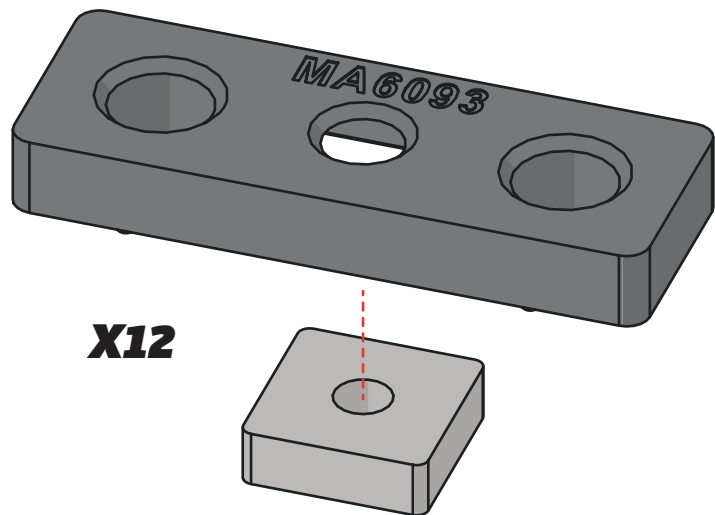
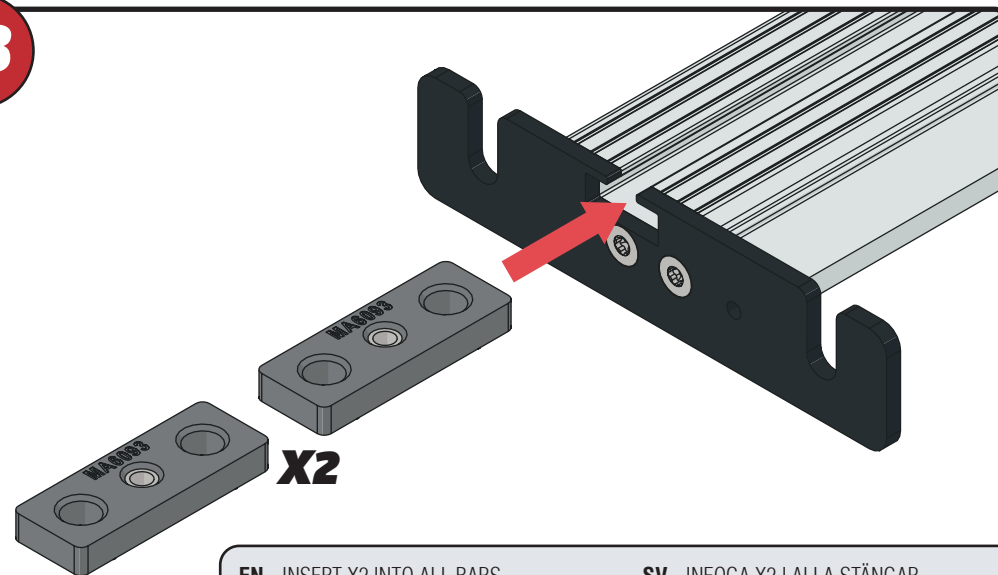
12**13**

EN - INSERT X2 INTO ALL BARS

DE - X2 IN ALLE STANGEN EINFÜGEN

FR - INSÉRER X2 DANS TOUTES LES BARRES

NL - PLAATS X2 IN ALLE BARS

ES - INSERTAR X2 EN TODAS LAS BARRAS

IT - INSERIRE X2 IN TUTTE LE BARRE

SV - INFOGA X2 I ALLA STÄNGAR

DA - INDSÆT X2 I ALLE STÆNGER

NO - SETT X2 INN I ALLE TAKSTENGER

PL - WSTAW X2 DO WSZYSTKICH PRĘTÓW

CS - VLOŽTE X2 DO VŠECH TYČÍ

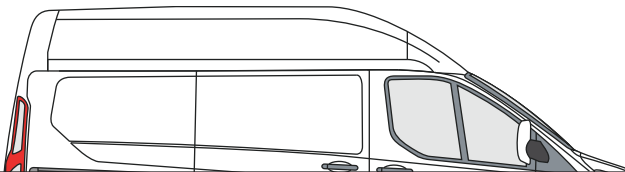
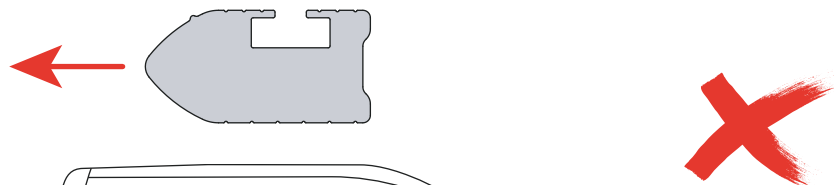
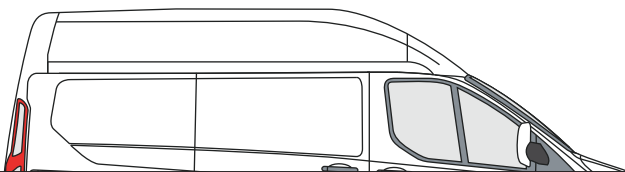
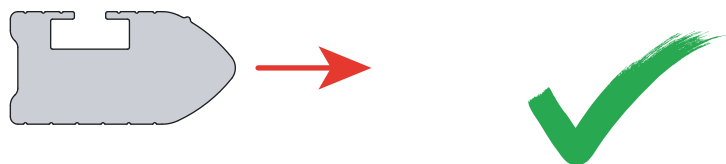
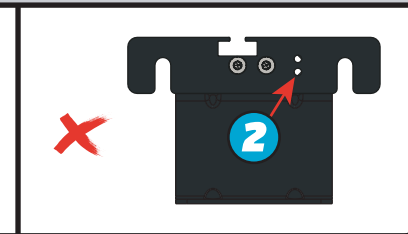
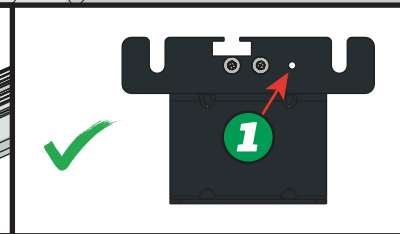
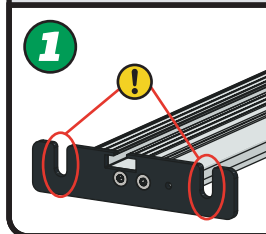
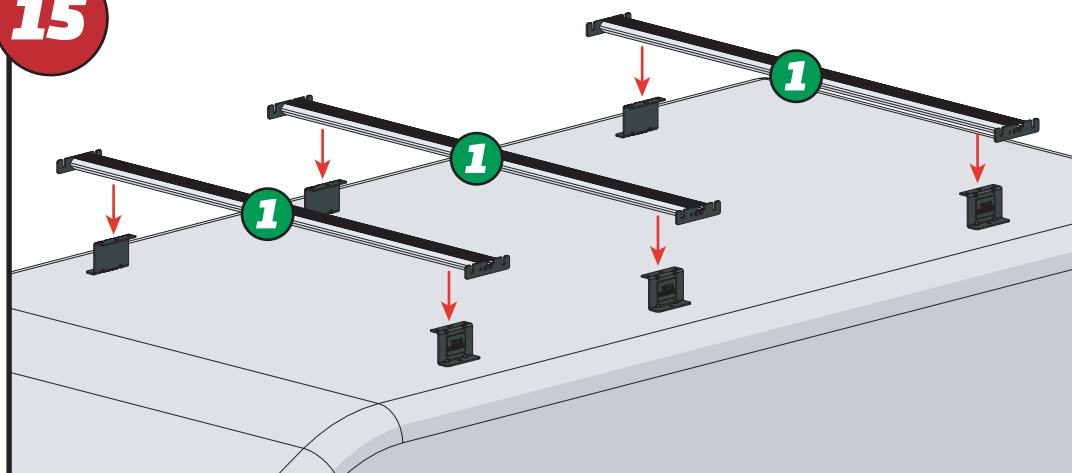
14**15**

16

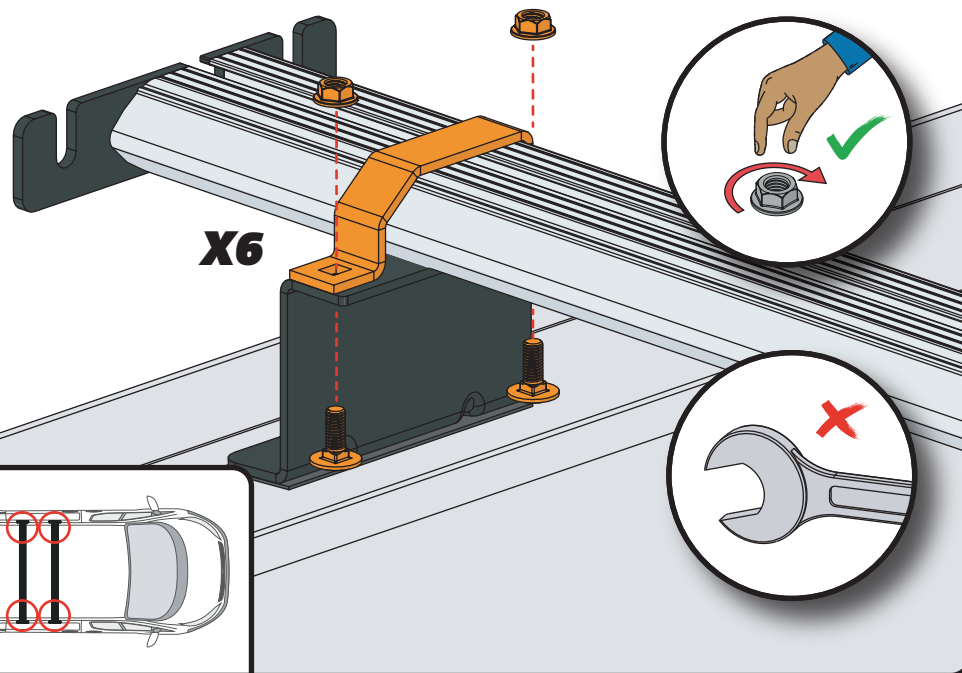

17

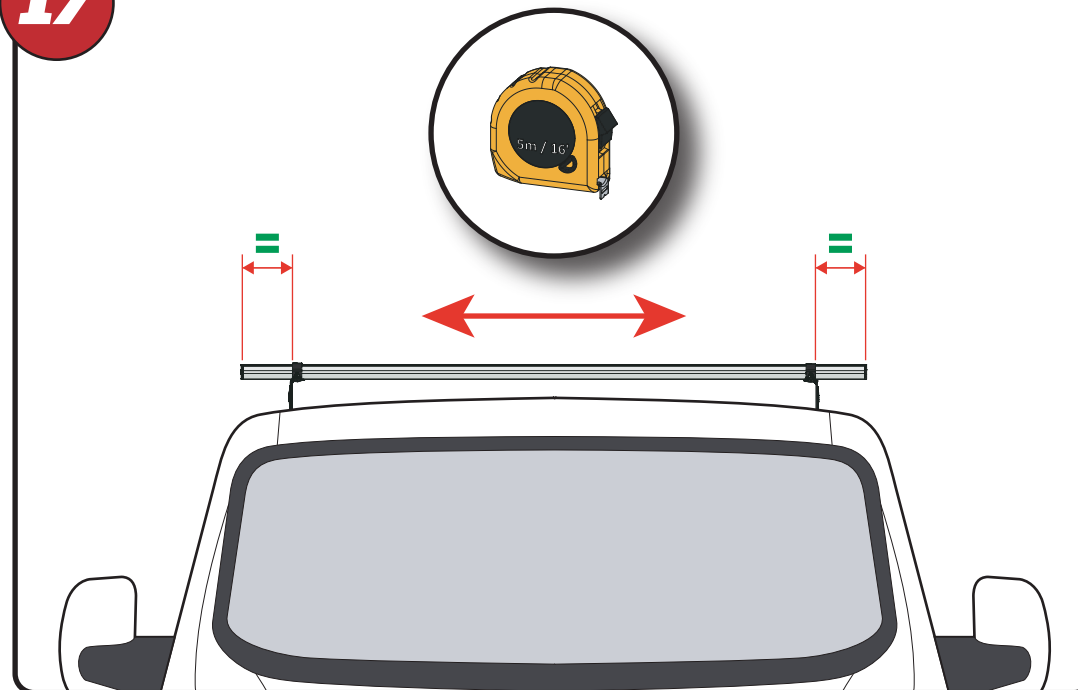

18

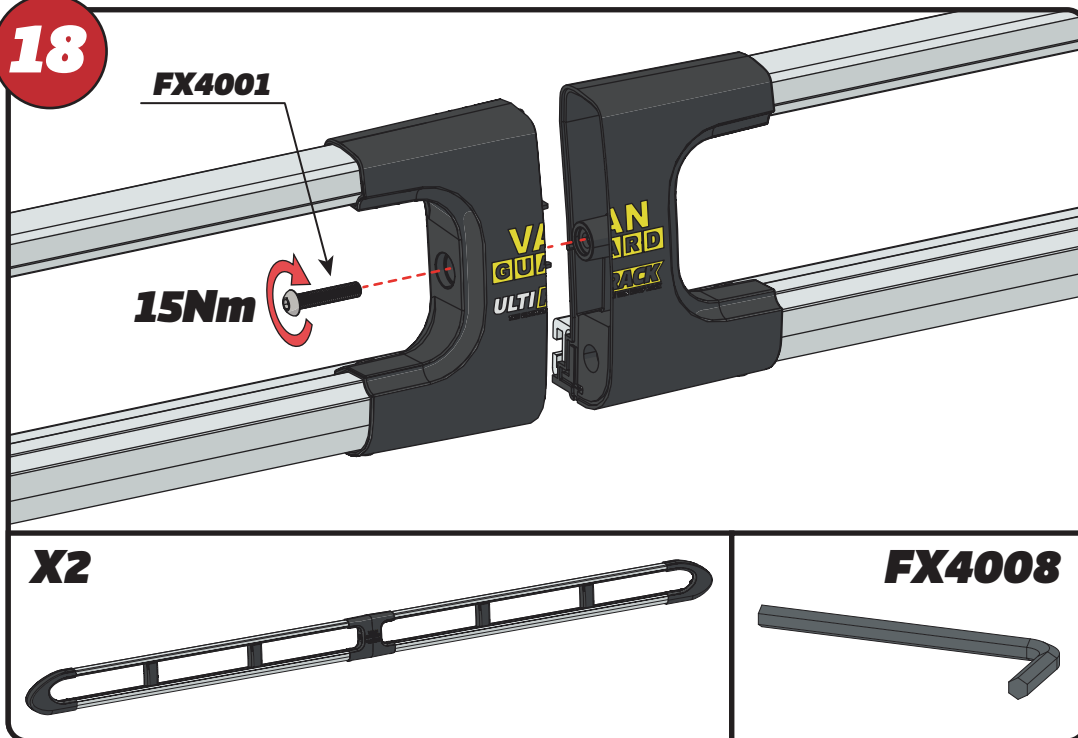

19

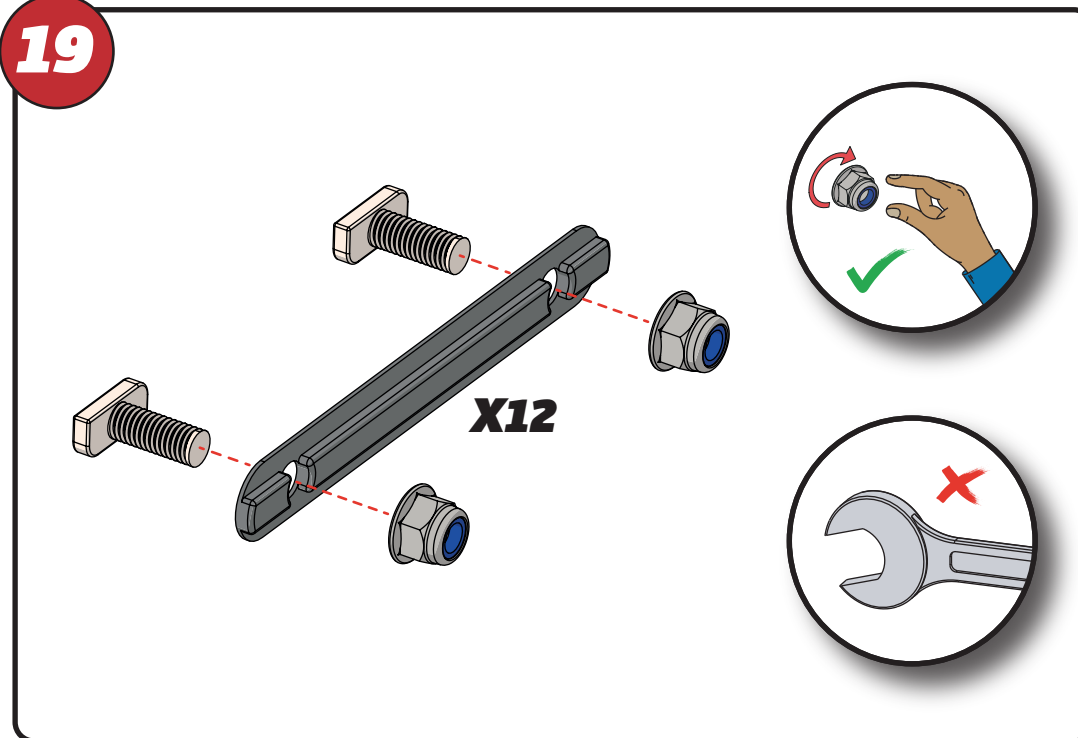

20

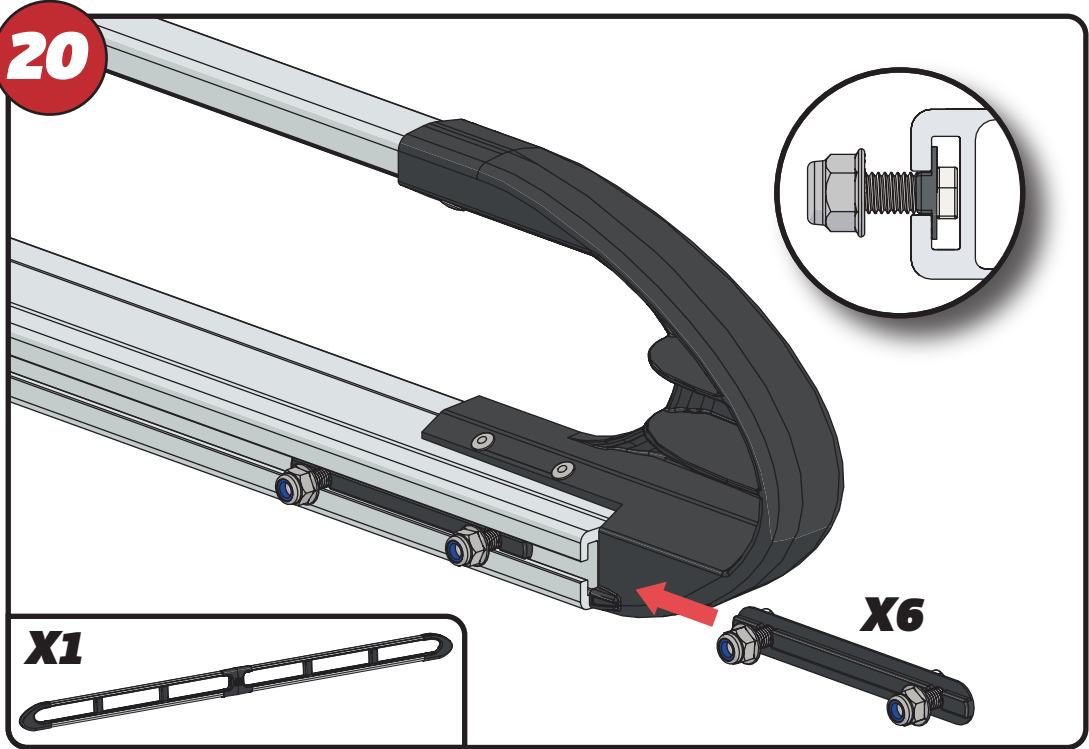

21

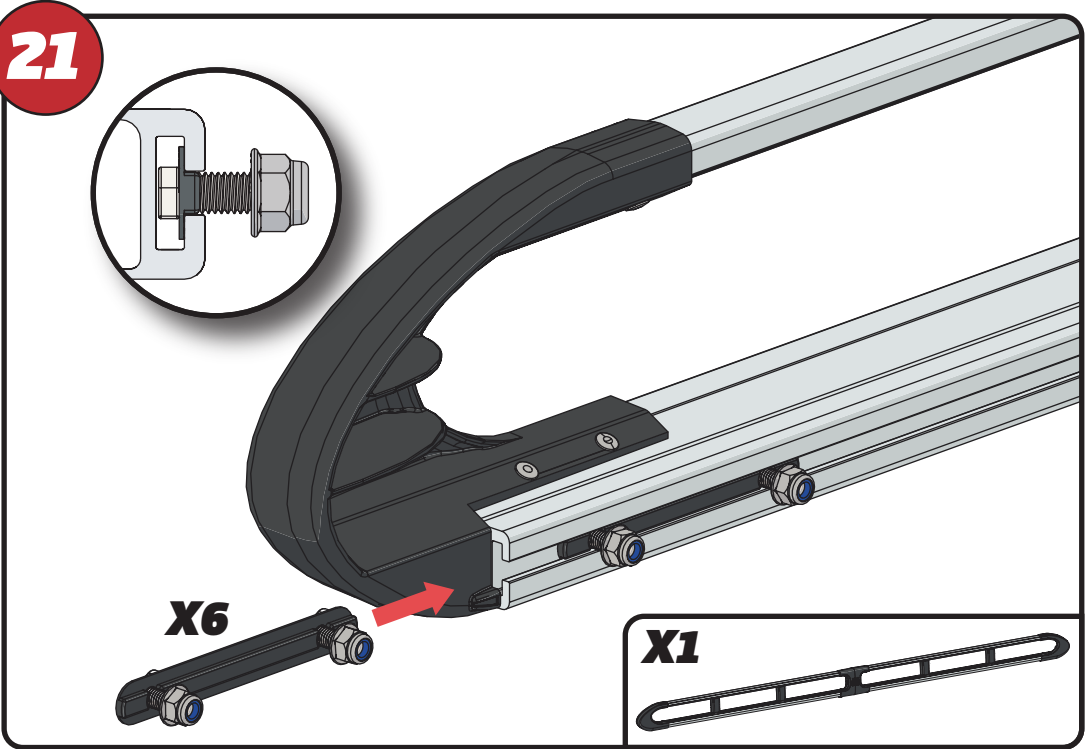

22

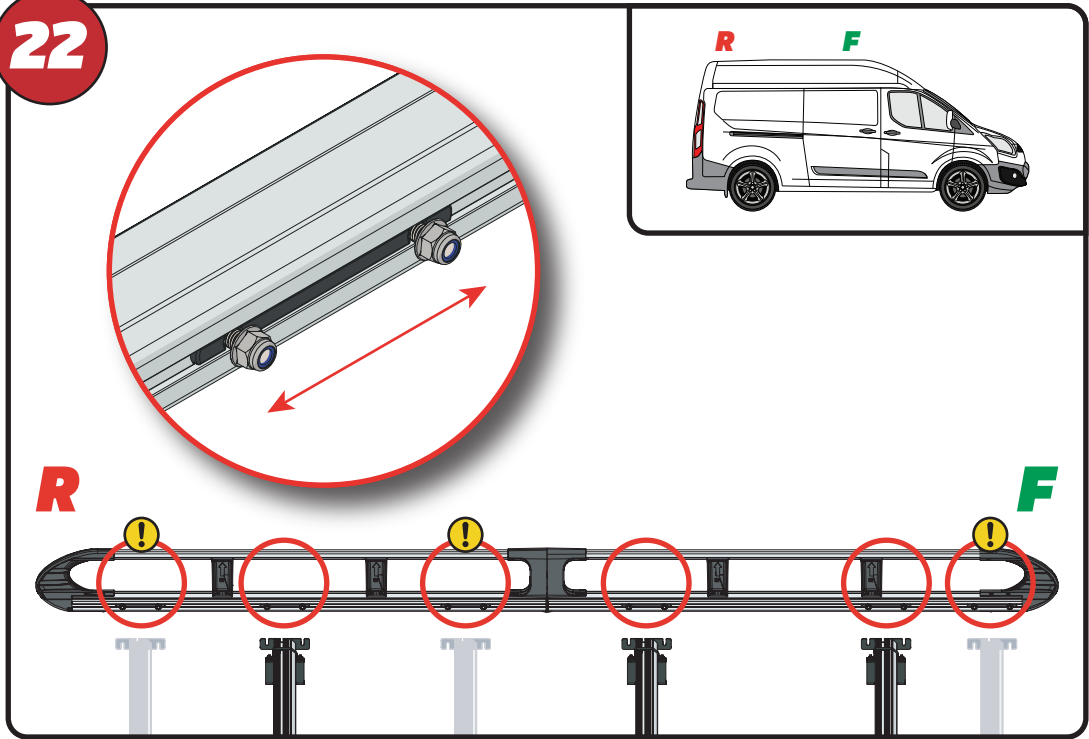

23

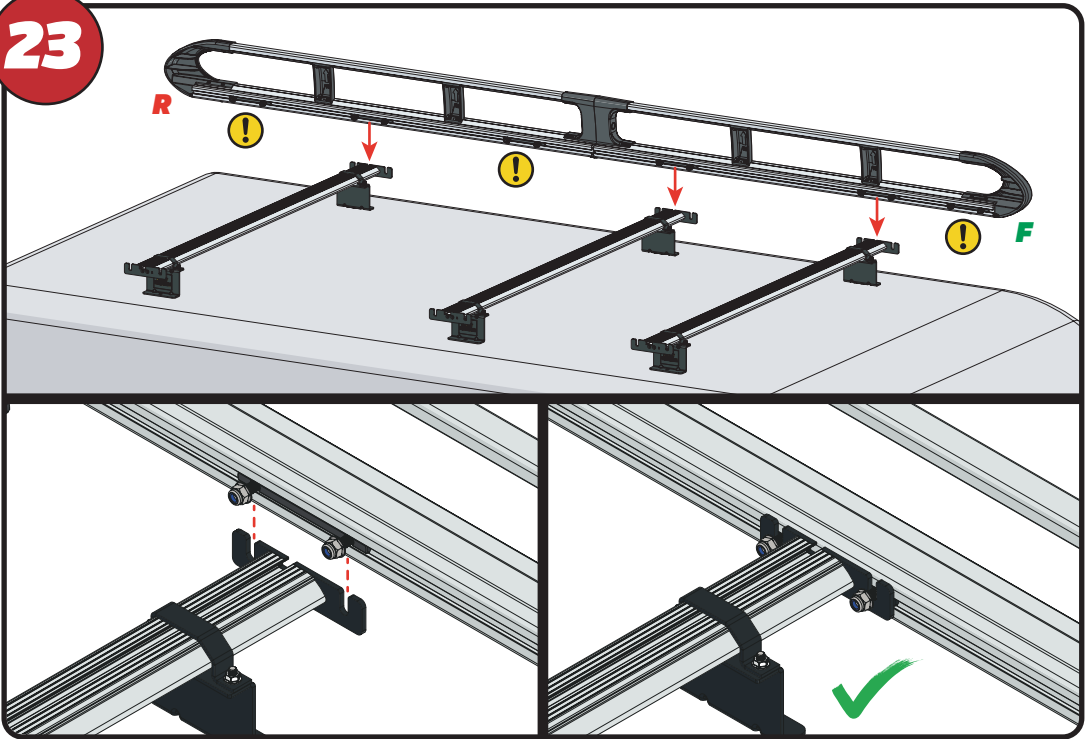

24

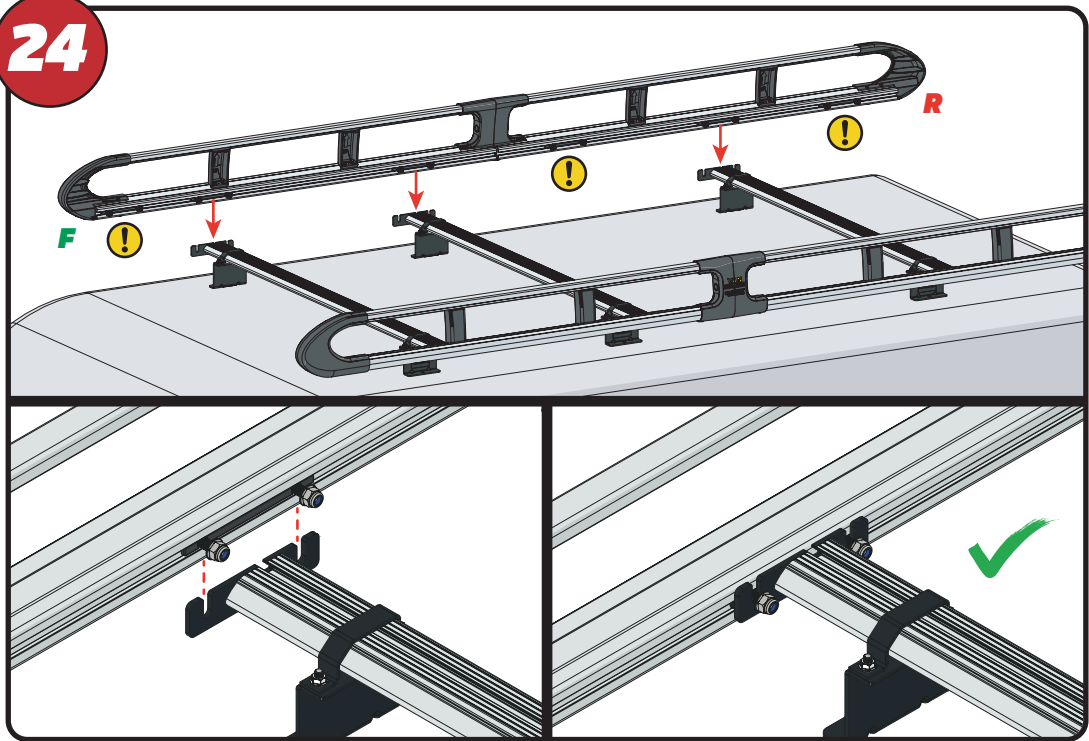

25

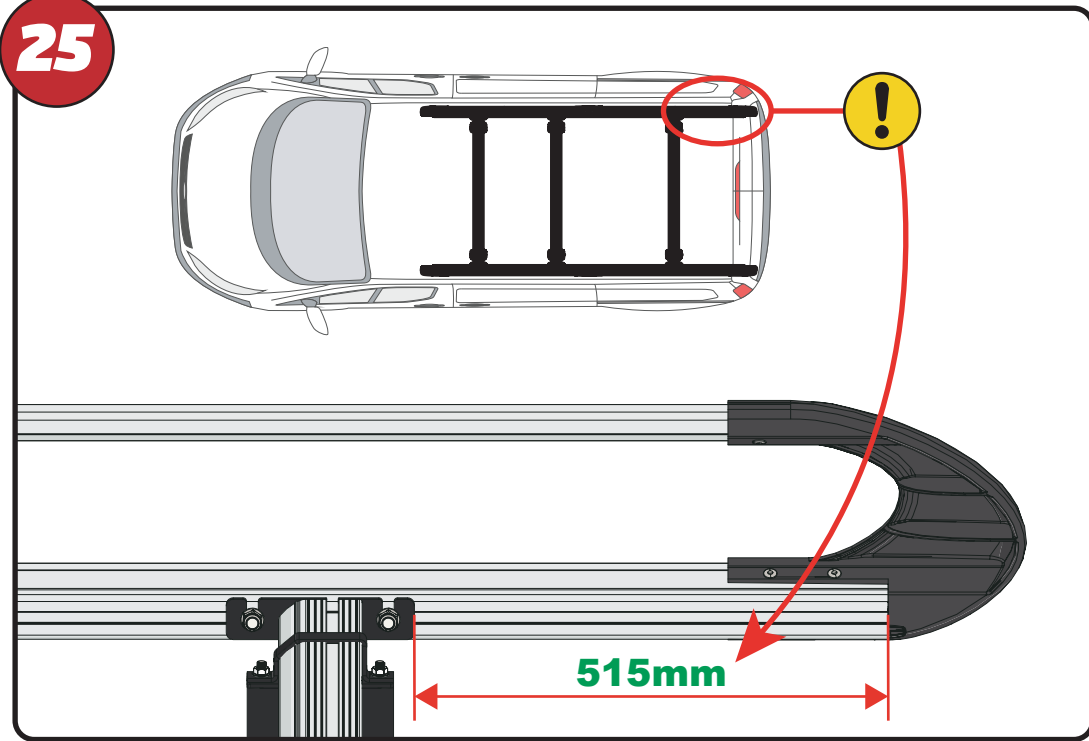

26

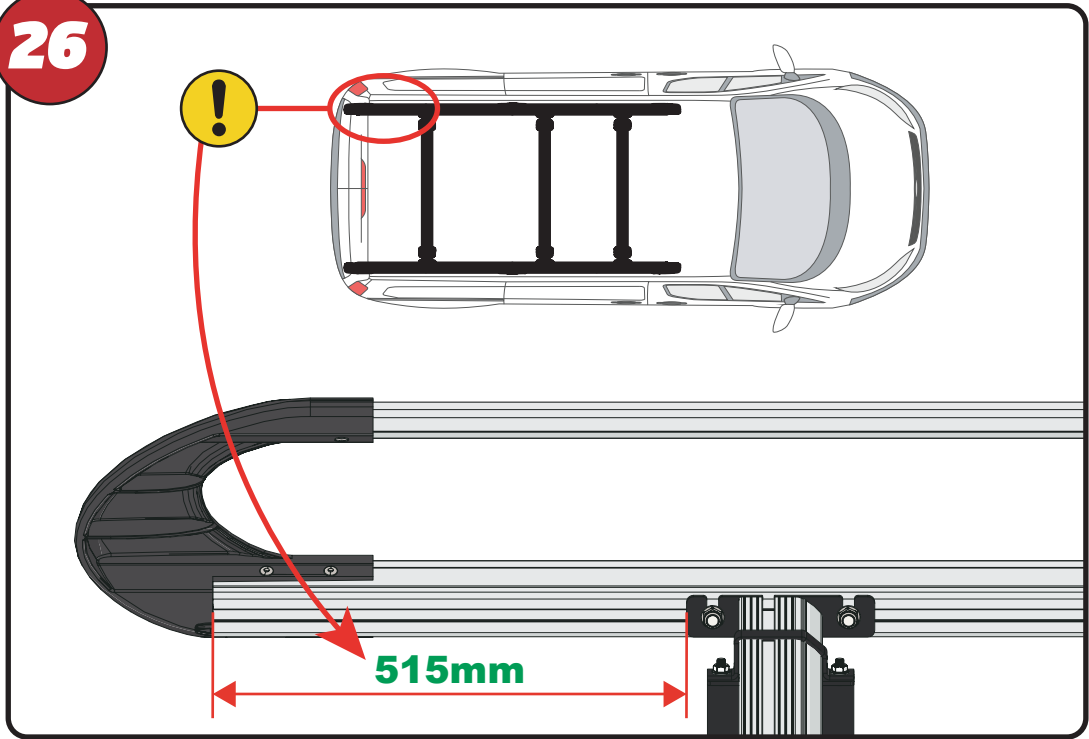

27

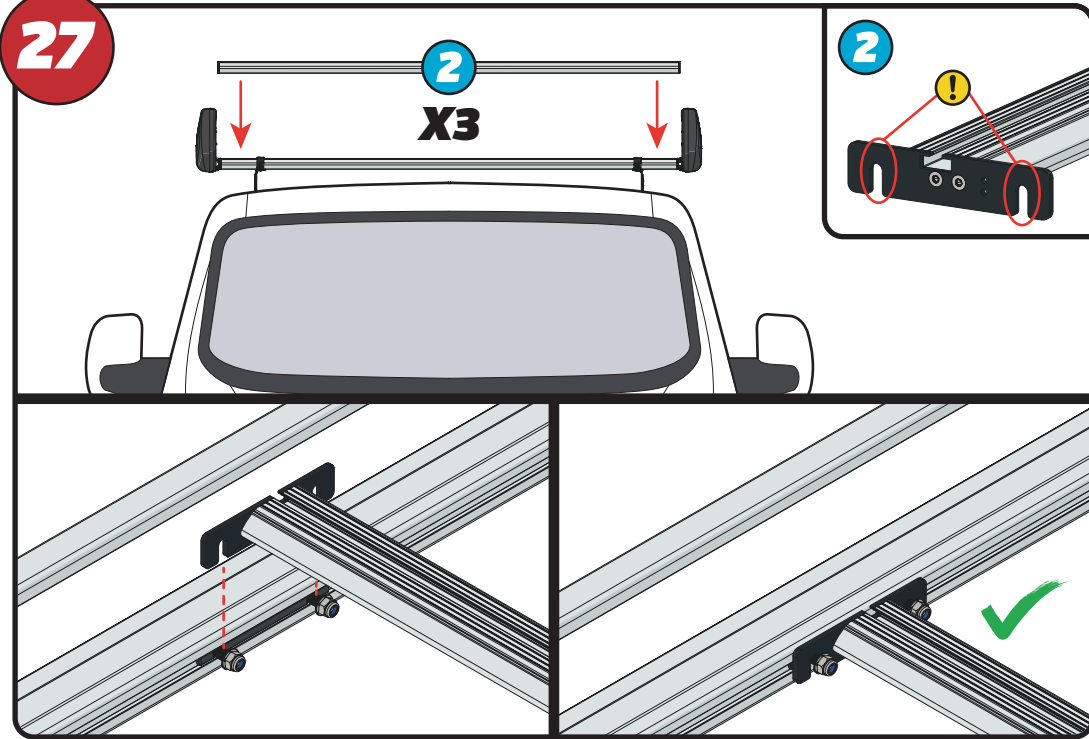

28

XXX =
PAGE 2 OF 15

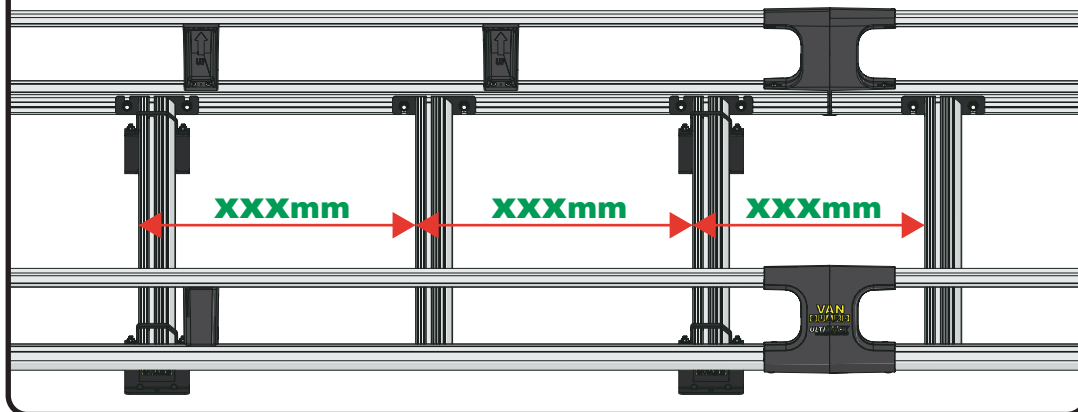
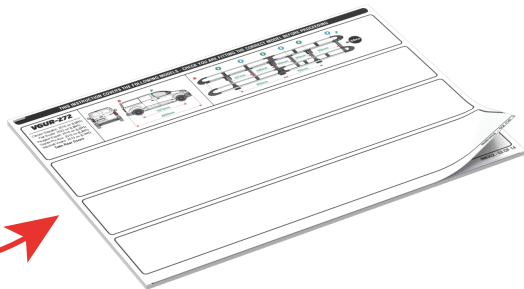
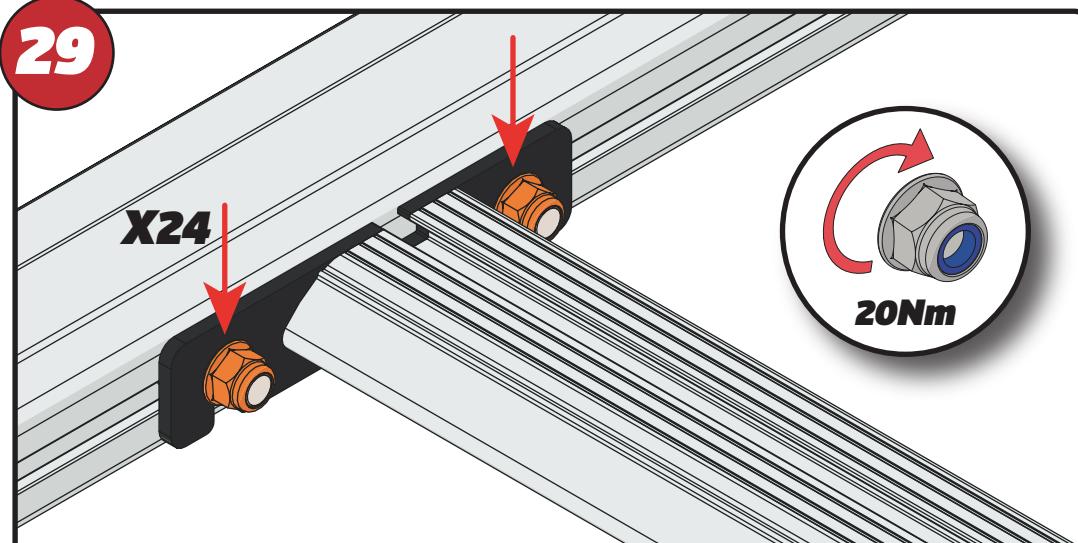
**29****X24****20Nm**

EN - TIGHTEN ALL OF THE CROSS BARS
DE - ALLE QUERSTANGEN FESTZIEHEN
FR - SERREZ TOUTES LES BARRES TRANSVERSALES
NL - DRAAI ALLE DWARSBALK VAN HET DAK AAN
ES - APRIETE TODAS LAS BARRAS TRANSVERSALES
IT - STRINGERE TUTTE LE BARRE TRASVERSALI

SV - SKRU UPP ALLA KORSSTANGAR
DA - SKRU ALLE TAGBØJLER OP
NO - SKRU OPP ALLE TVERRSTENGER
PL - DOKRĘCIĆ WSZYSTKIE POPRZECZKI
CS - VŠECHNY PŘÍČNÉ TYČE SEŠROUJTE

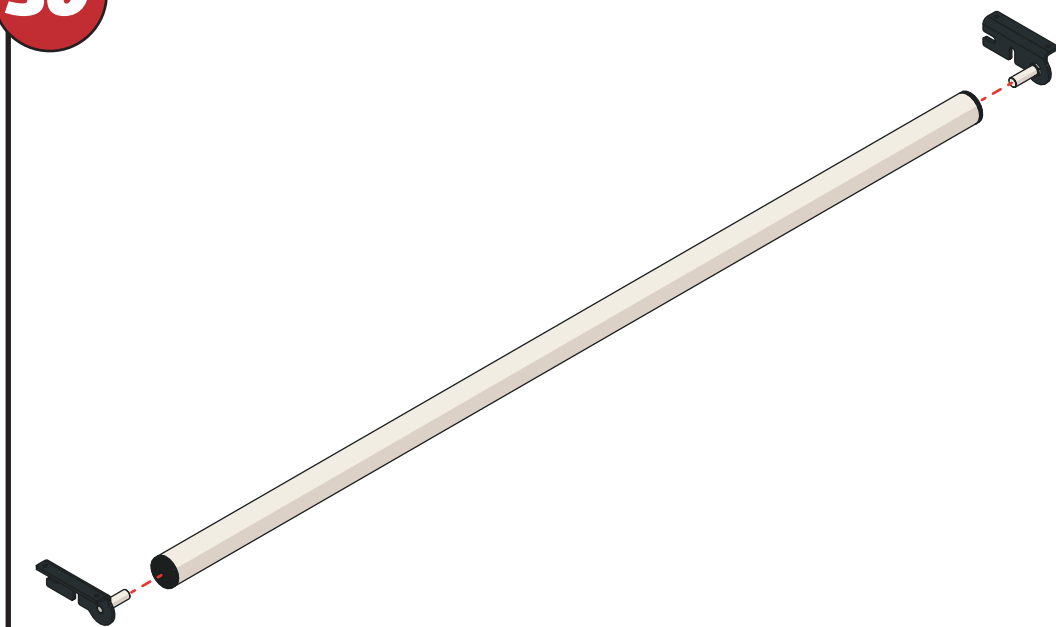
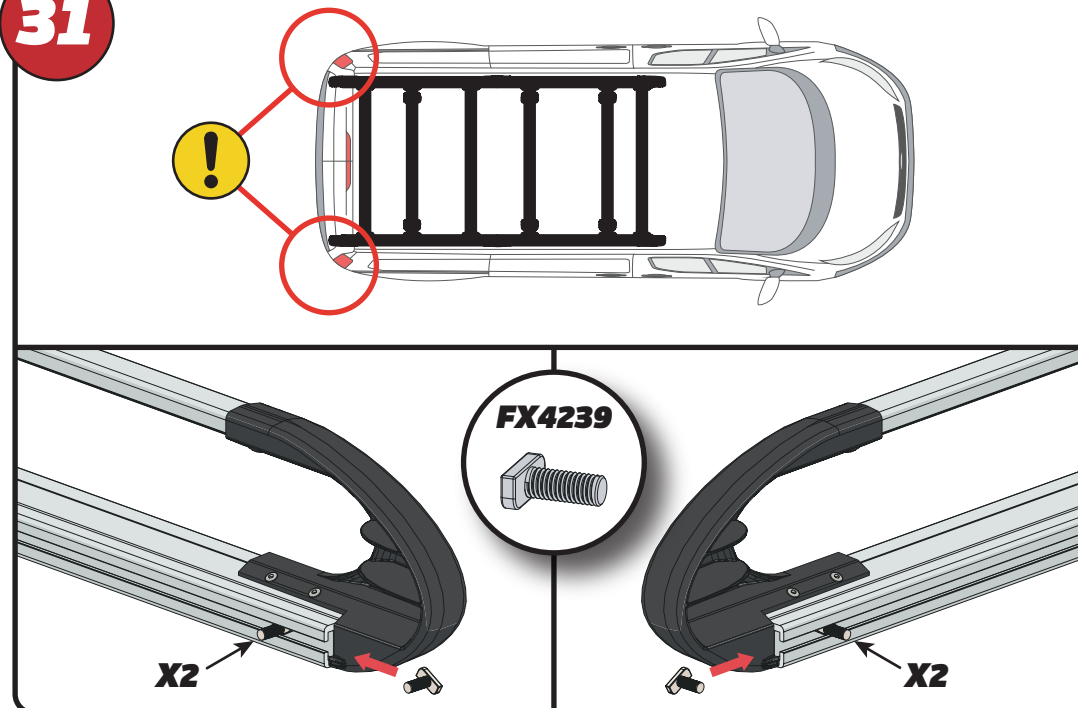
30**31****FX4239****X2****X2**

32

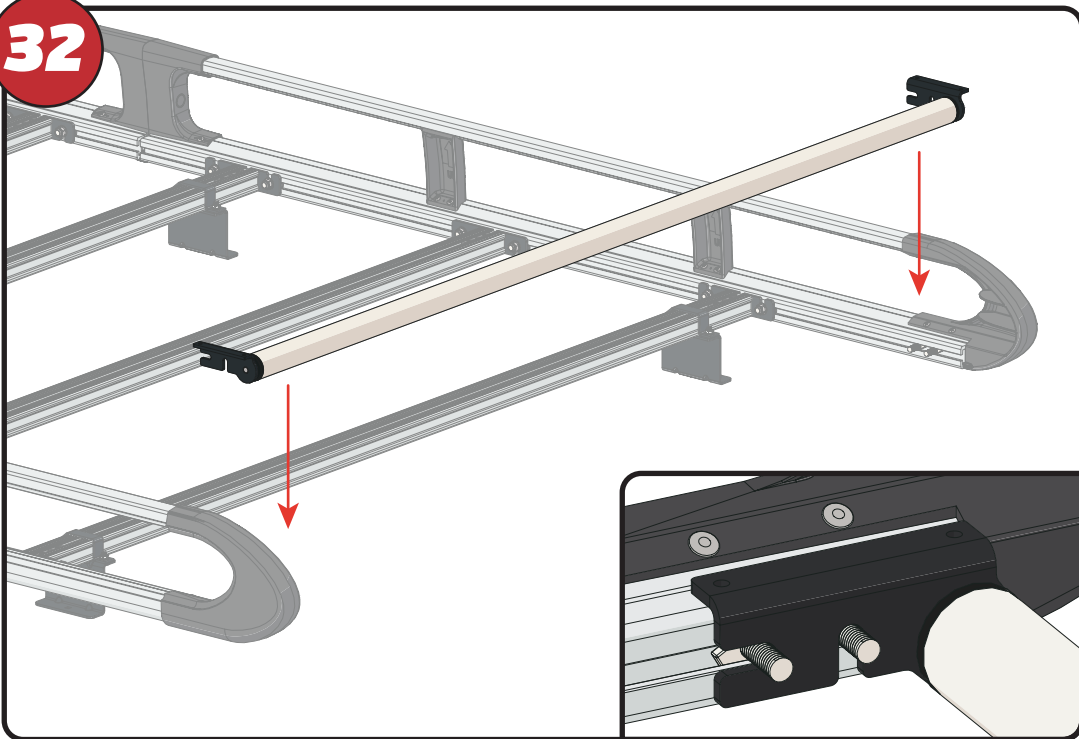

33

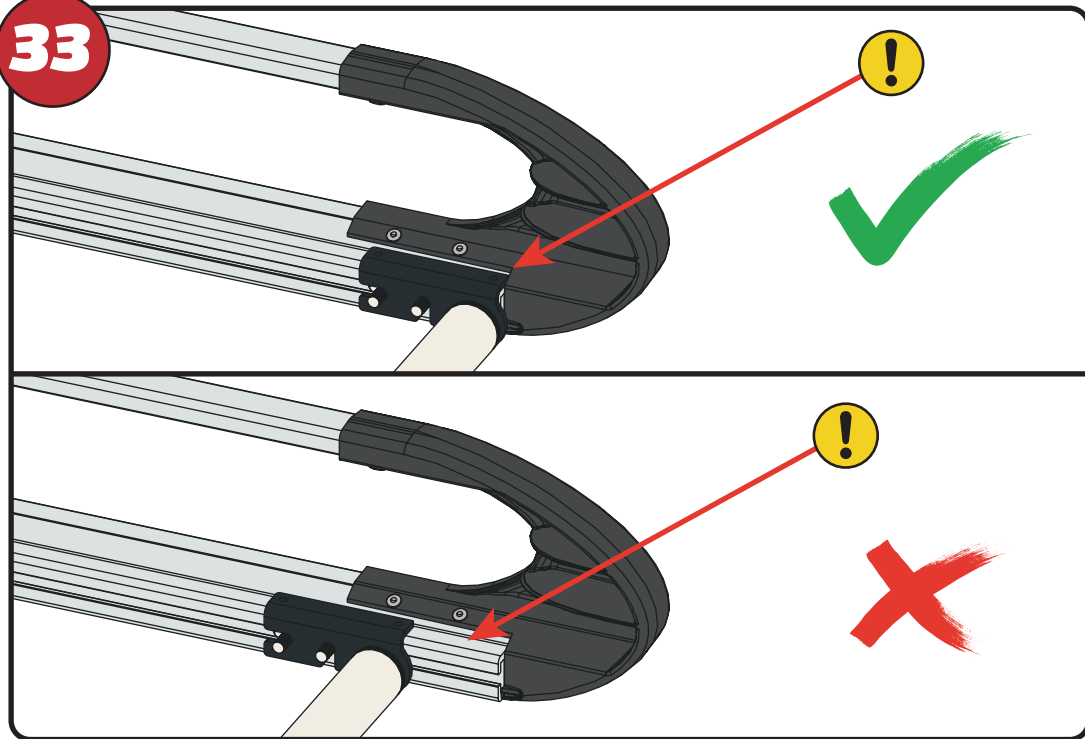

34

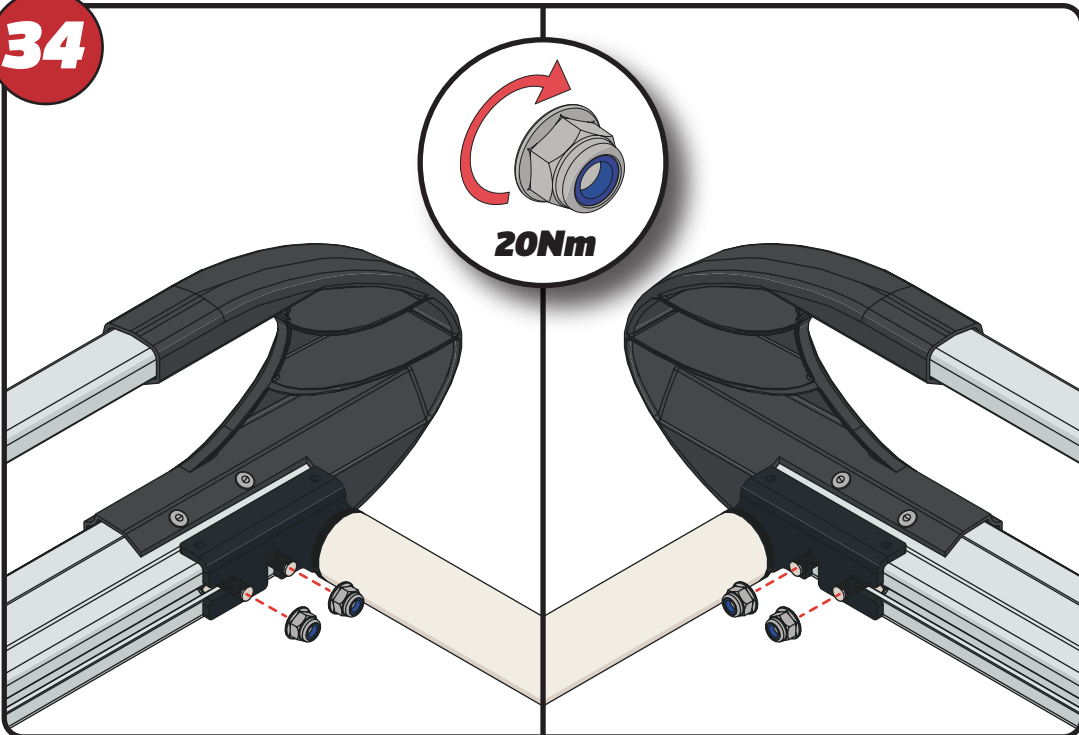

35

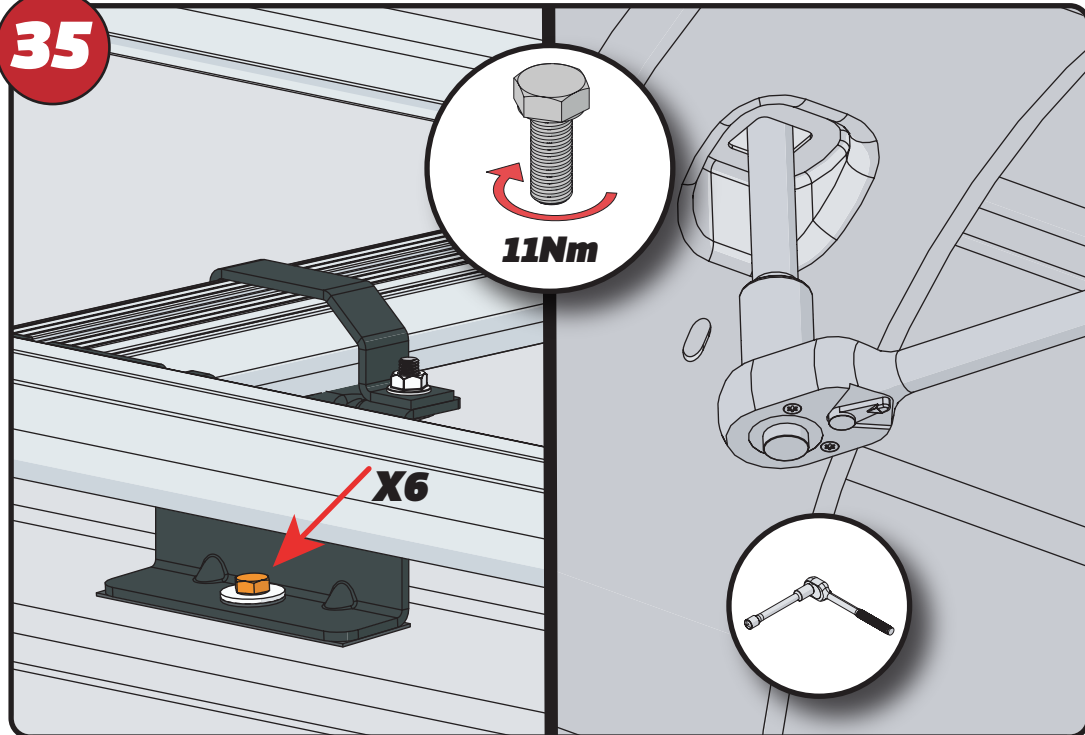

36

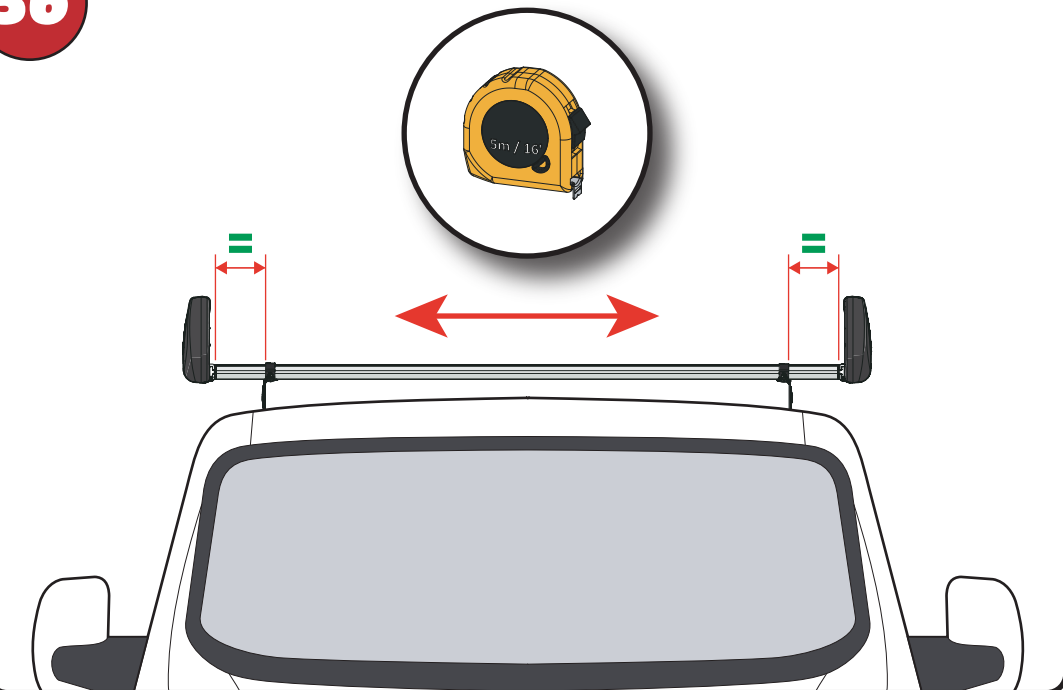

37

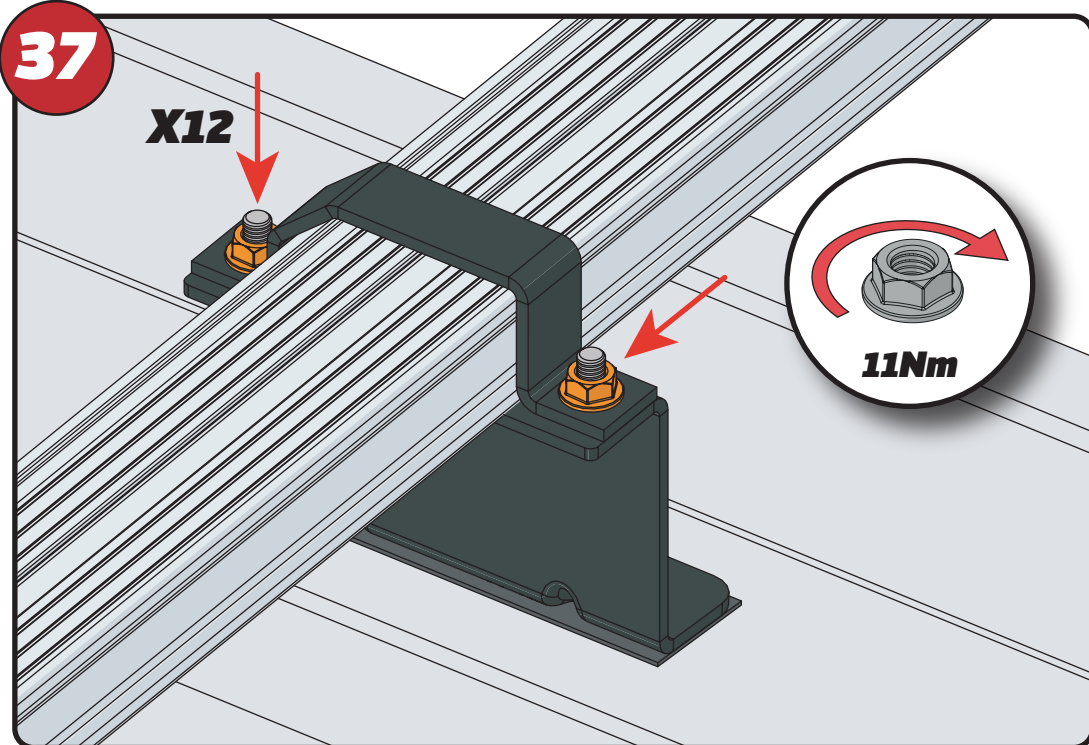

38

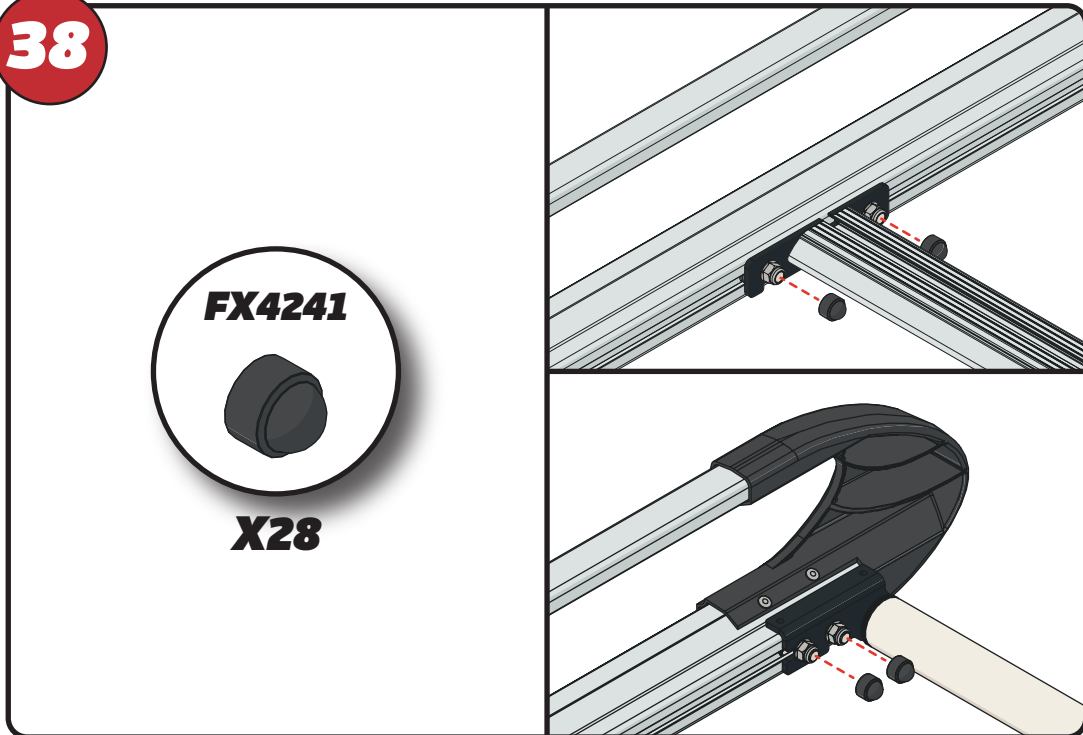

39

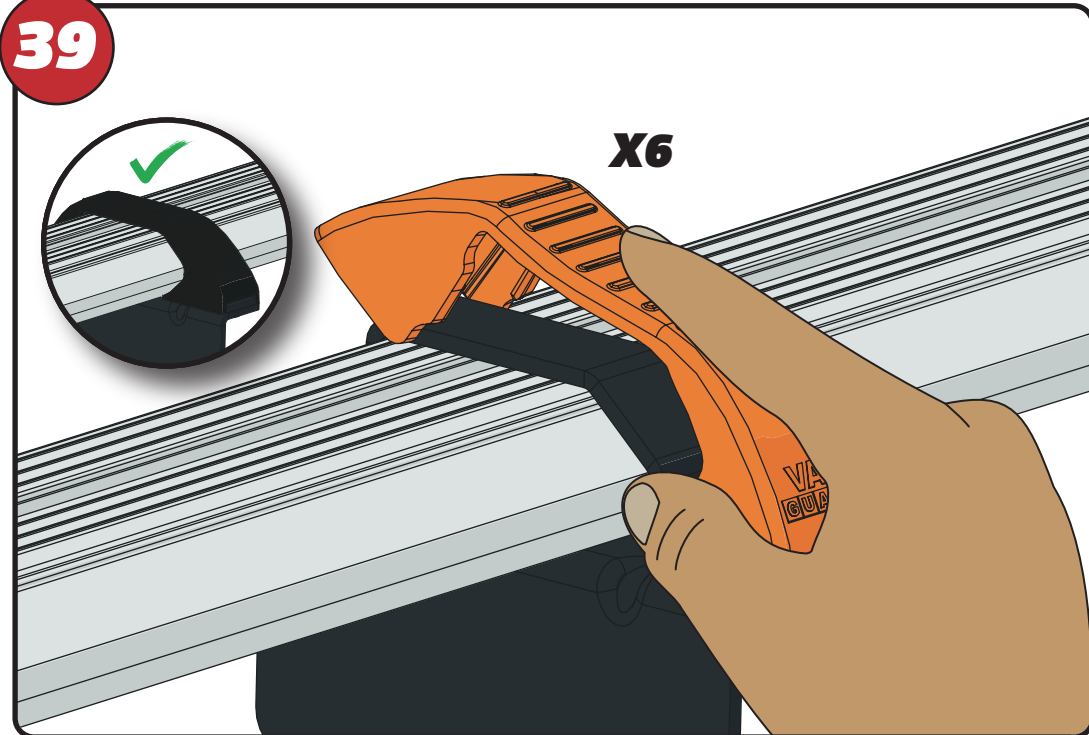

40

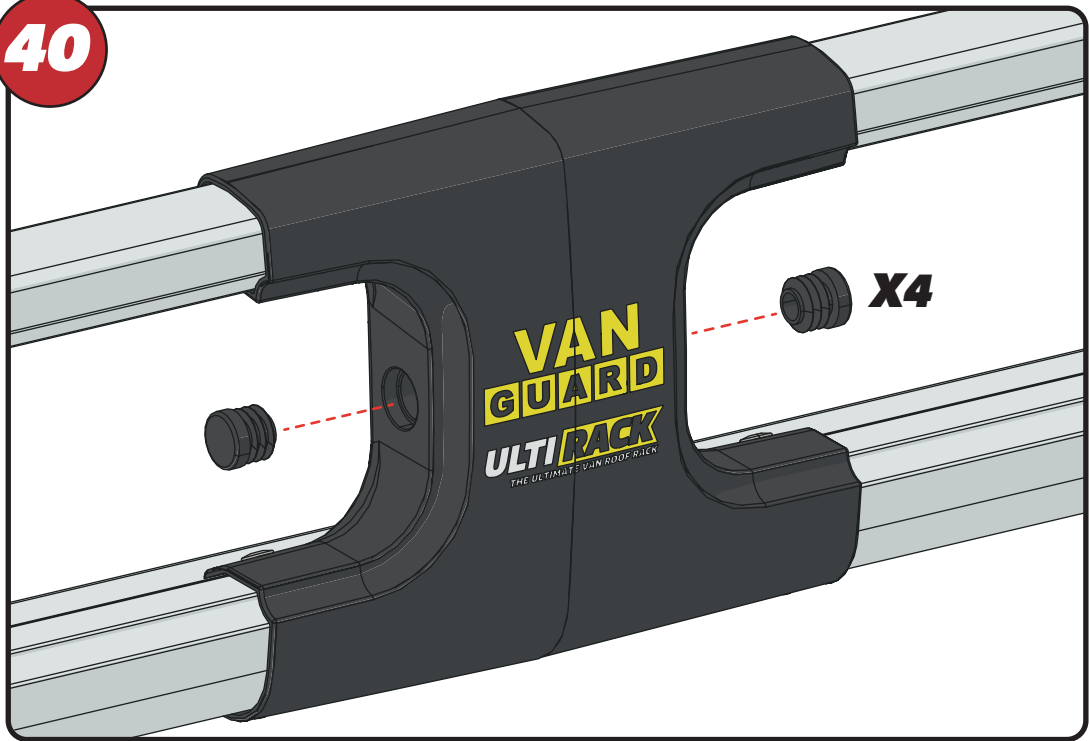

41

