

# IN8438

## ULTI Rack+

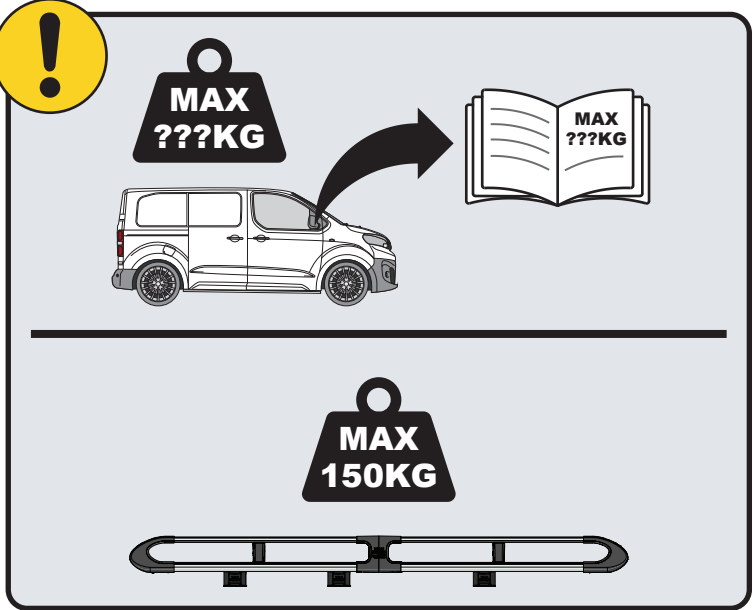

 [Customercare@van-guard.co.uk](mailto:Customercare@van-guard.co.uk)  
UK +44 (0) 1392 368 351

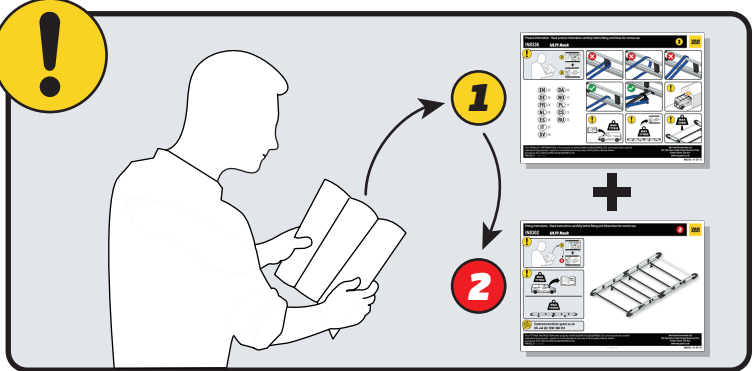

This FITTING INSTRUCTION is the property of VAN GUARD ACCESSORIES LTD. and must not be used for manufacturing purposes, copied nor communicated in any way to third parties without written permission from VAN GUARD ACCESSORIES LTD.  
IN8438\_A (CN:NR)

Van Guard Accessories Ltd  
Fair Oak Close, Exeter Airport Business Park,  
Exeter, Devon, EX5 2UL  
[www.van-guard.co.uk](http://www.van-guard.co.uk)

THIS INSTRUCTION COVERS THE FOLLOWING MODELS - CHECK YOU ARE FITTING THE CORRECT MODEL BEFORE PROCEEDING

### VGUR-300

Citroen Dispatch: 2016 on  
Peugeot Expert: 2016 on  
Toyota Pro-Ace: 2016 on  
**L1H1**  
Tailgate

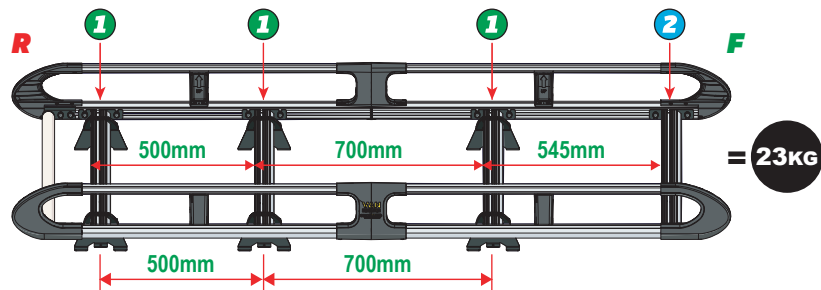
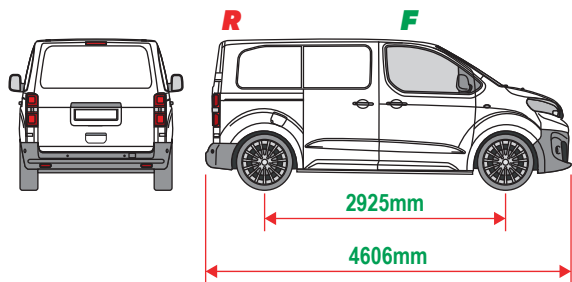

**SUPPLIED COMPONENTS - CHECK ALL PARTS ARE PRESENT AND CORRECT BEFORE PROCEEDING (1 OF 2)**

**TOOLS REQUIRED**

**10MM X1**



**13MM X1**

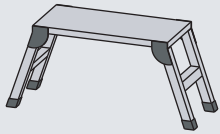
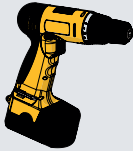

**AS3531 X2**  
(2000 / A)

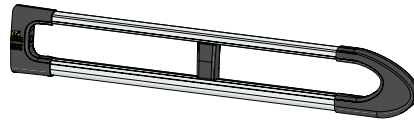

**MA6118 X8**

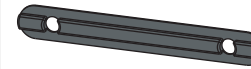

**FX4241 X20**

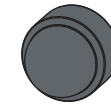

**ME1622 X1**

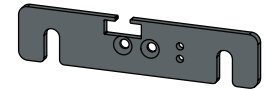

**AS3530 X2**  
(2000 / B)

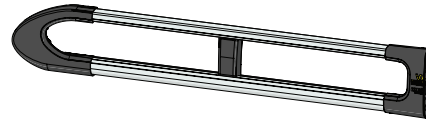

**FX4008 X1**



**MA6145 X1**

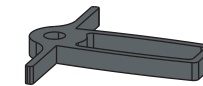

**ME1623 X1**

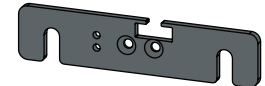

**ME1627 X4**  
(1354mm)

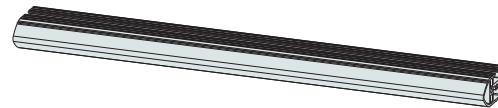

**FX4001 X2**  
(M8X40)



**FX4235 X16**  
(M5X25)



**ME0203 X6**

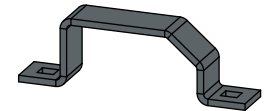

**AS3159 X1**  
(1340mm)

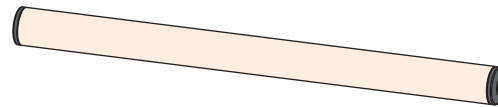

**MA6007 X4**

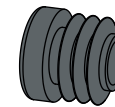

**FX4248 X1**  
(T25)

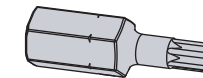

**MA6065 X6**

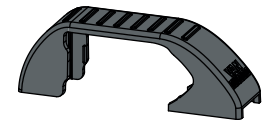

**AS3590 X1**

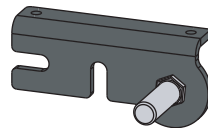

**MA6093 X8**

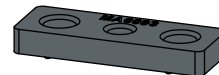

**FX4239 X20**  
(M8X20)

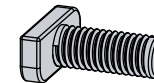

**ME1620 X3**

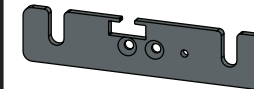

**FX4016 X12**  
(M6)



**AS3591 X1**

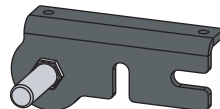

**ME0316 X8**

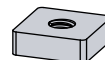

**FX4240 X20**  
(M8)



**ME1621 X3**

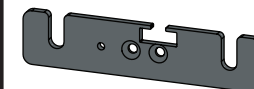

**FX4042 X12**  
(M6X16)

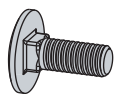

SUPPLIED COMPONENTS - CHECK ALL PARTS ARE PRESENT AND CORRECT BEFORE PROCEEDING (2 OF 2)

**ME0823 X1**

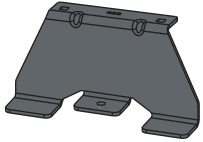

**FX4012 X6**

(M6X16)

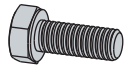

**ME0824 X1**

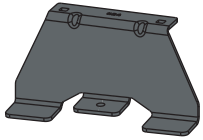

**FX4017 X6**

(M6)



**ME0825 X2**

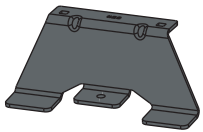

**FX4126 X6**

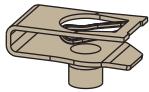

**ME0841 X1**

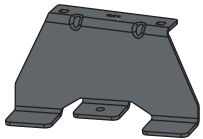

**MA6081 X12**

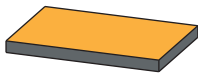

**ME0842 X1**

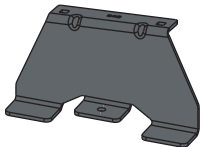

**FX4010 X6**

(M6)



**01**

**1L**

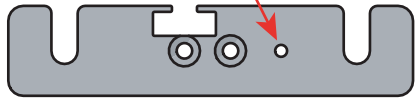

**X3**

**1R**

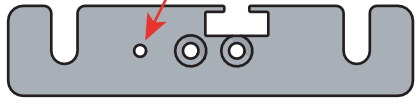

**X3**



**2L**



**X1**

**2R**

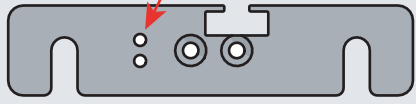

**X1**

**02**

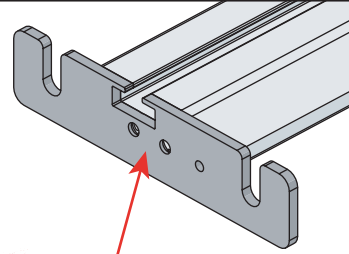
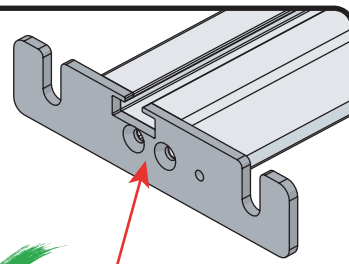

**03**

**01**

**FX4248**

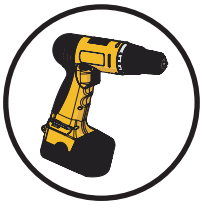

**+**

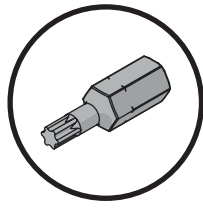

**02**

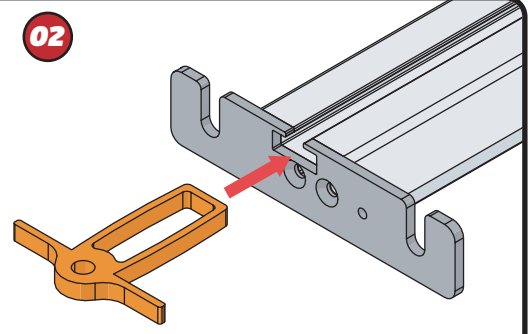

**03**



**11Nm**

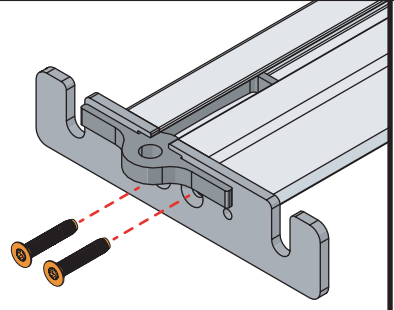

**04**

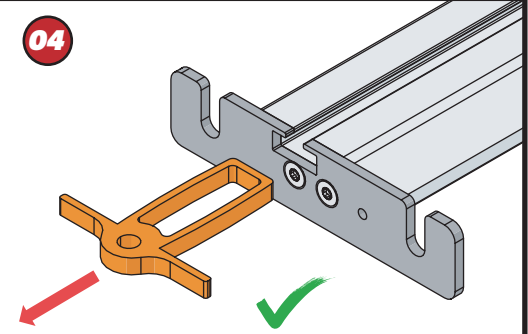

**04**



**1**

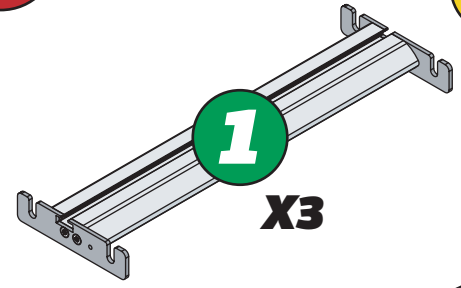

**X3**

**2**

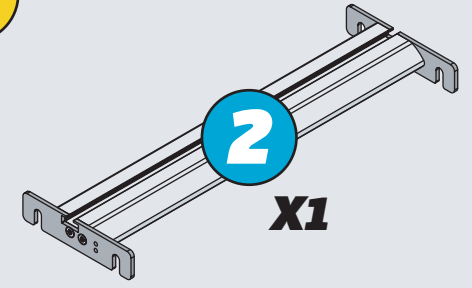

**X1**

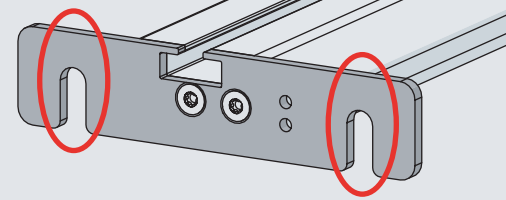
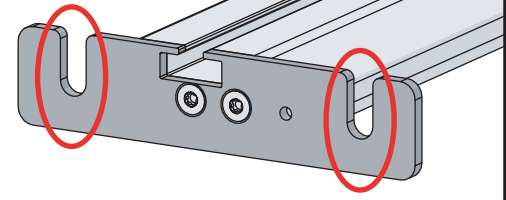

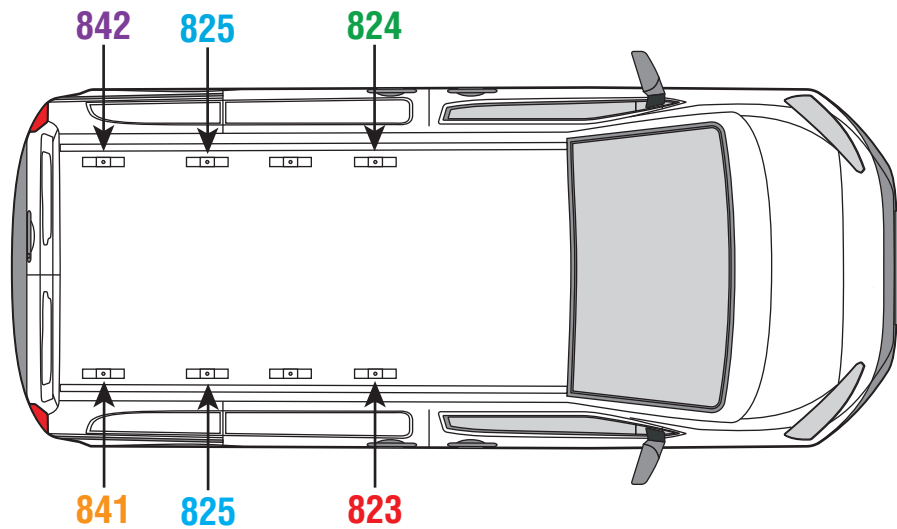
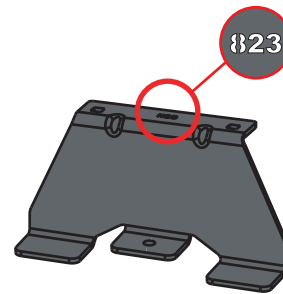
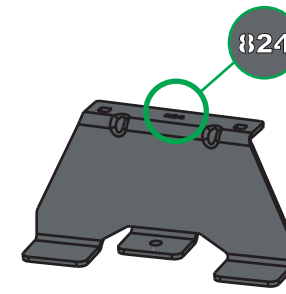
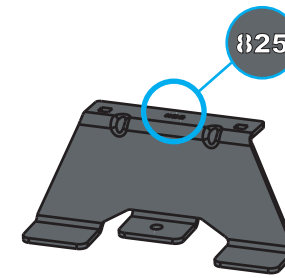
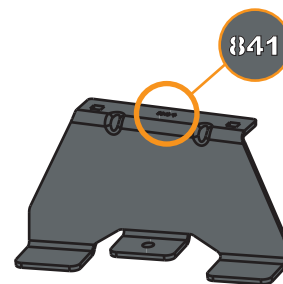
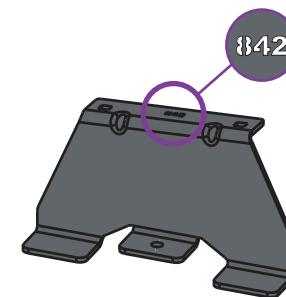
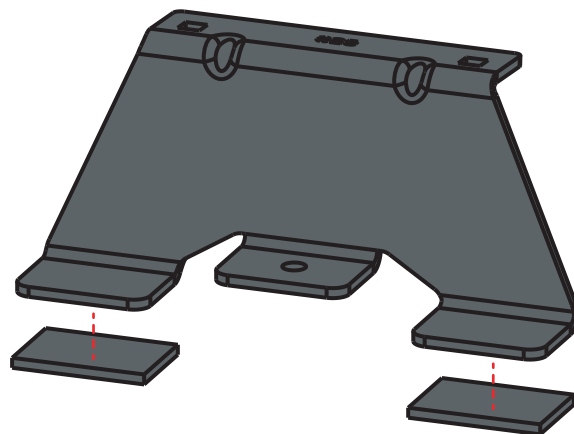
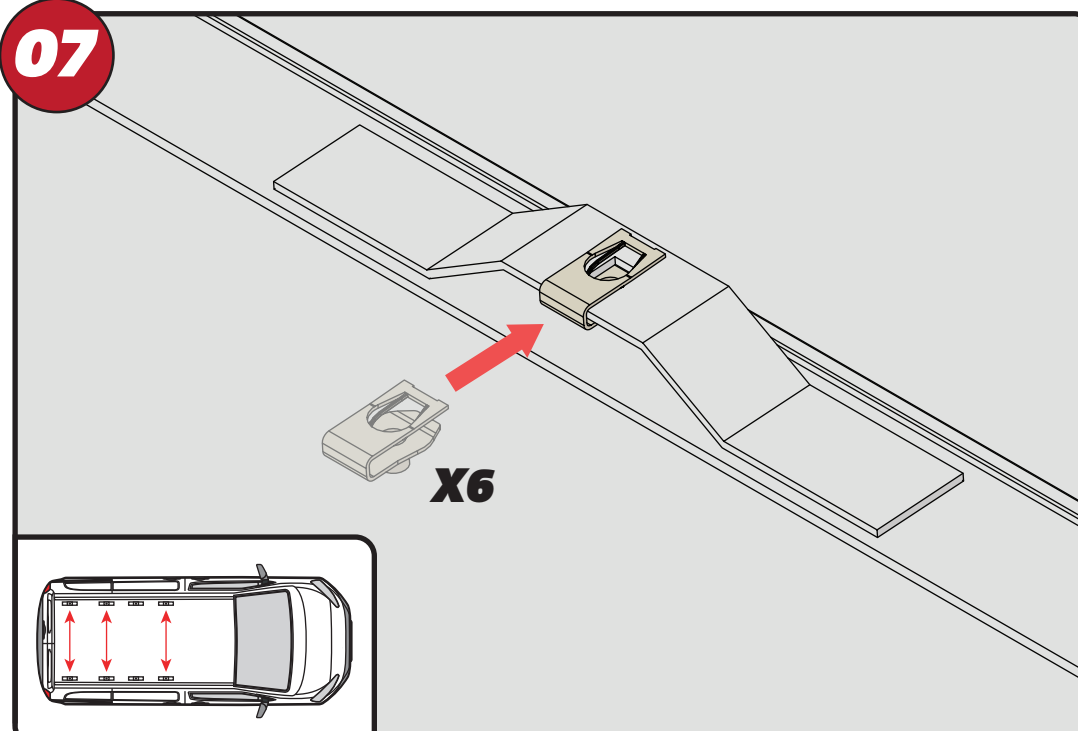
**05****823****824****825****841****842****06****07**

EN - STICK GASKETS TO ALL BRACKETS  
 DE - KLEBEN SIE DIE DICHTUNG AN ALLEN HALTERUNGEN  
 FR - COUSSINETS ADHÉSIFS À TOUS LES SUPPORTS  
 NL - PLAK PAKKING OP ALLE BEUGELS  
 ES - PEGA LAS ALMOHADILLAS A TODOS LOS SOPORTES  
 IT - ADESIVI GUARNIZIONI A TUTTE LE STAFFE

SV - FÄST GUMMI PÅ ALLA FÄSTEN  
 DA - KLÆB GUMMI PÅ ALLE BESLAG  
 NO - PLIST GUMMI PÅ ALLE BRAKKETTER  
 PL - NAKLEJ USZCZELKI DO WSZYSTKICH WSPORNIKÓW  
 CS - PŘILEPTE TĚSNĚNÍ NA VŠECHNY DRŽÁKY

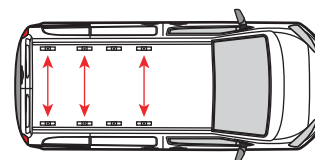

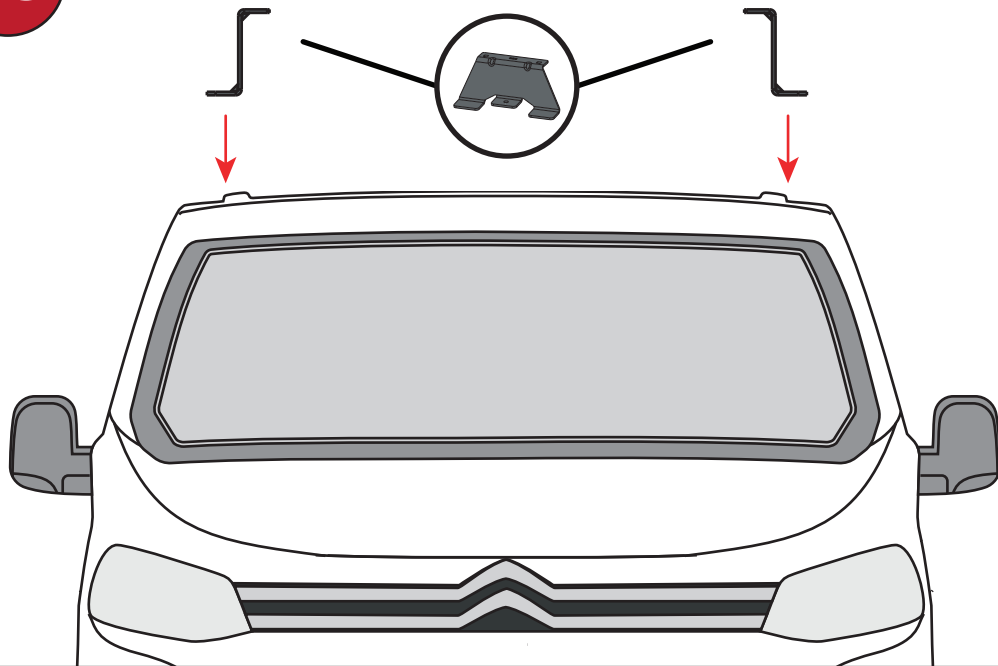
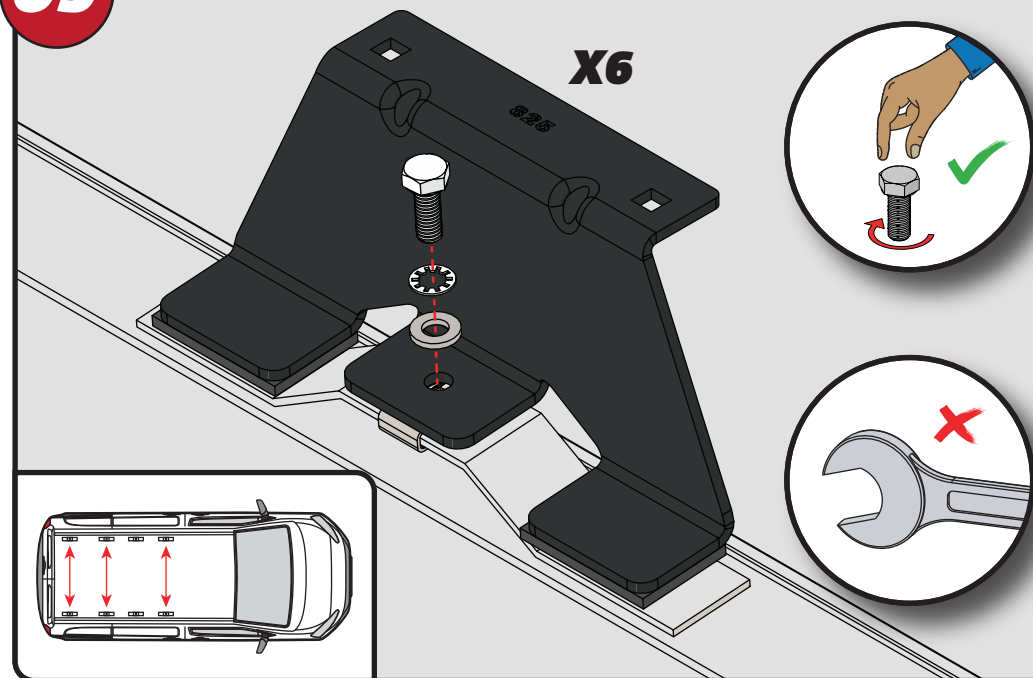
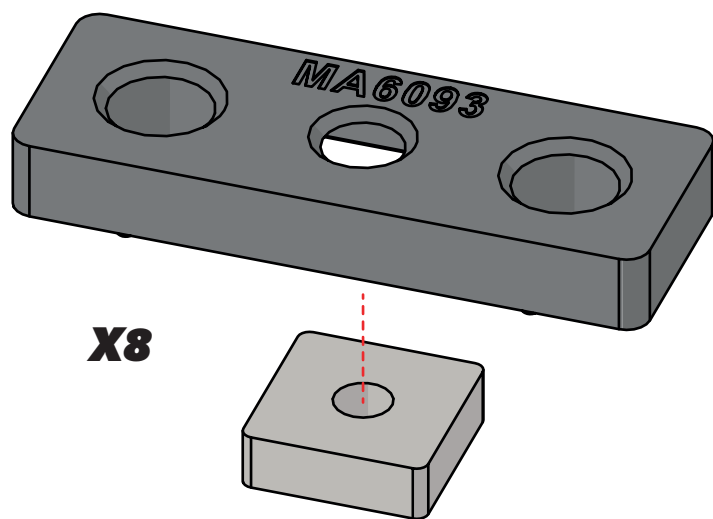
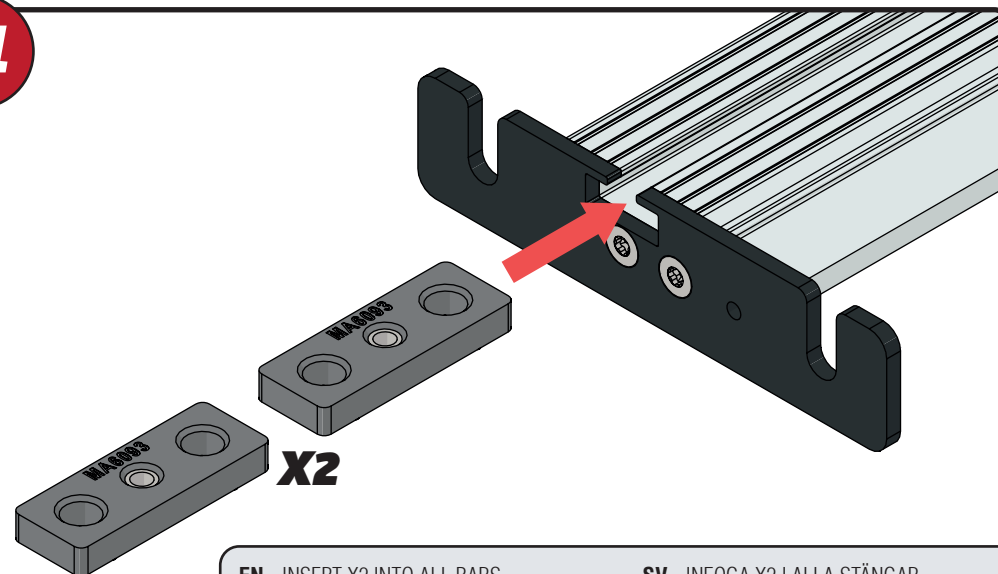
**08****09****10****11**

EN - INSERT X2 INTO ALL BARS  
 DE - X2 IN ALLE STANGEN EINFÜGEN  
 FR - INSÉRER X2 DANS TOUTES LES BARRES  
 NL - PLAATS X2 IN ALLE BARS  
 ES - INSERTAR X2 EN TODAS LAS BARRAS  
 IT - INSERIRE X2 IN TUTTE LE BARRE

SV - INFOGA X2 I ALLA STÄNGAR  
 DA - INDSÆT X2 I ALLE STÆNGER  
 NO - SETT X2 INN I ALLE TAKSTENGER  
 PL - WSTAW X2 DO WSZYSTKICH PRĘTÓW  
 CS - VLOŽTE X2 DO VŠECH TYČÍ

12

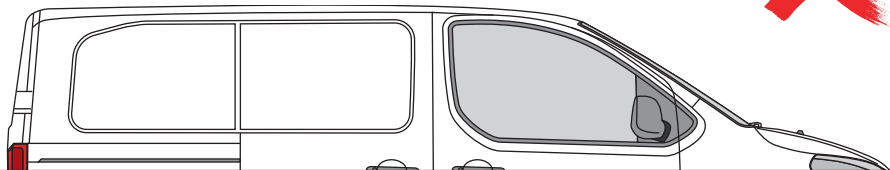
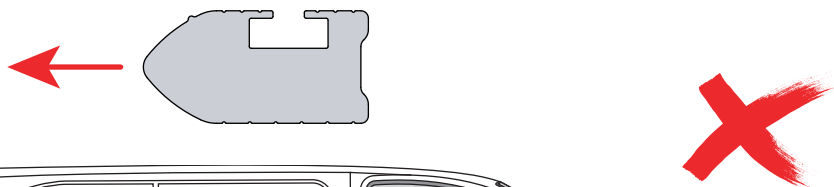
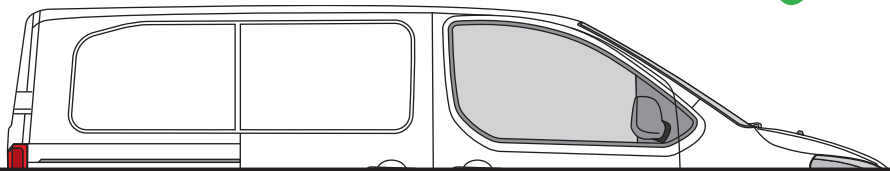

13

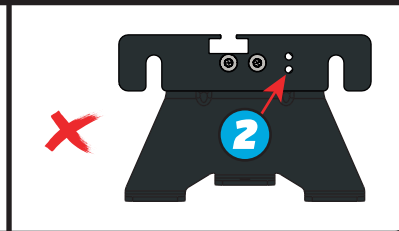
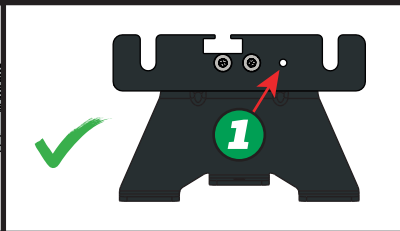
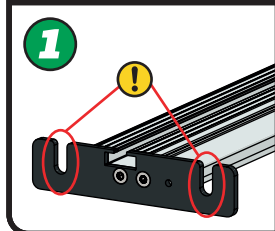
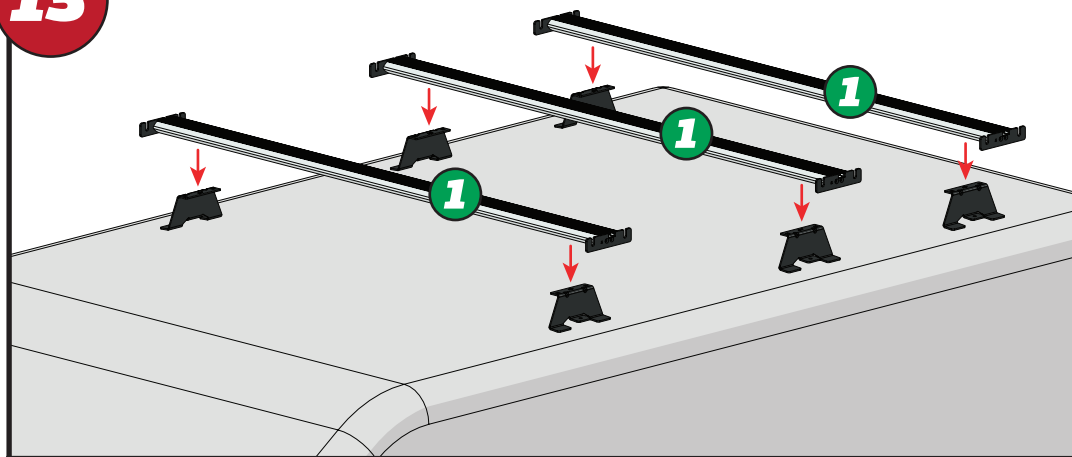

14

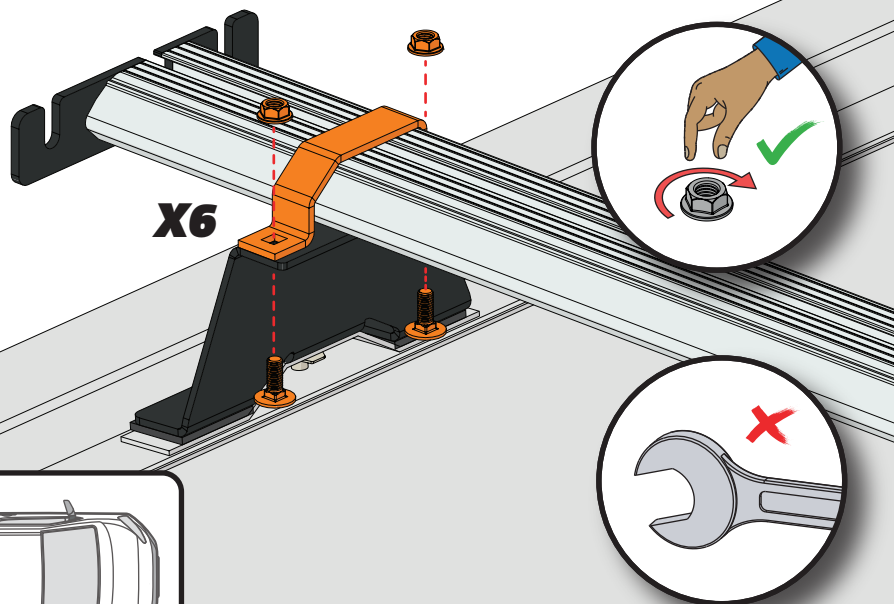

X6

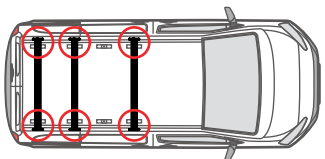
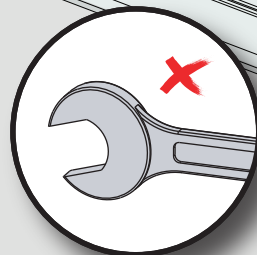

15

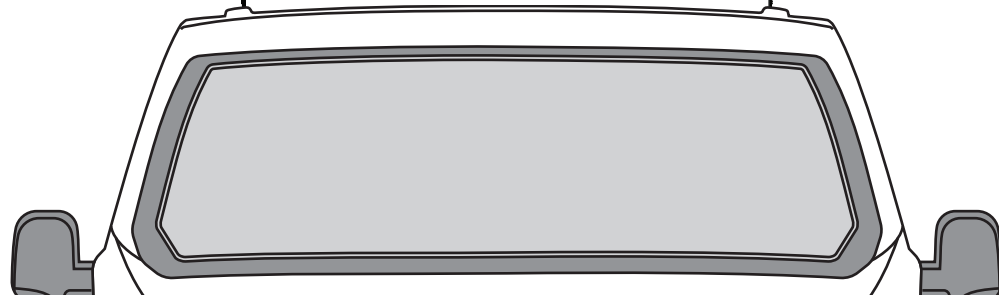
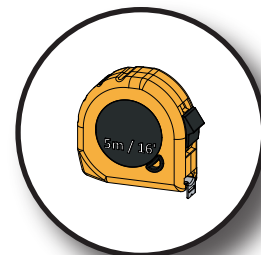

16

FX4001

15Nm

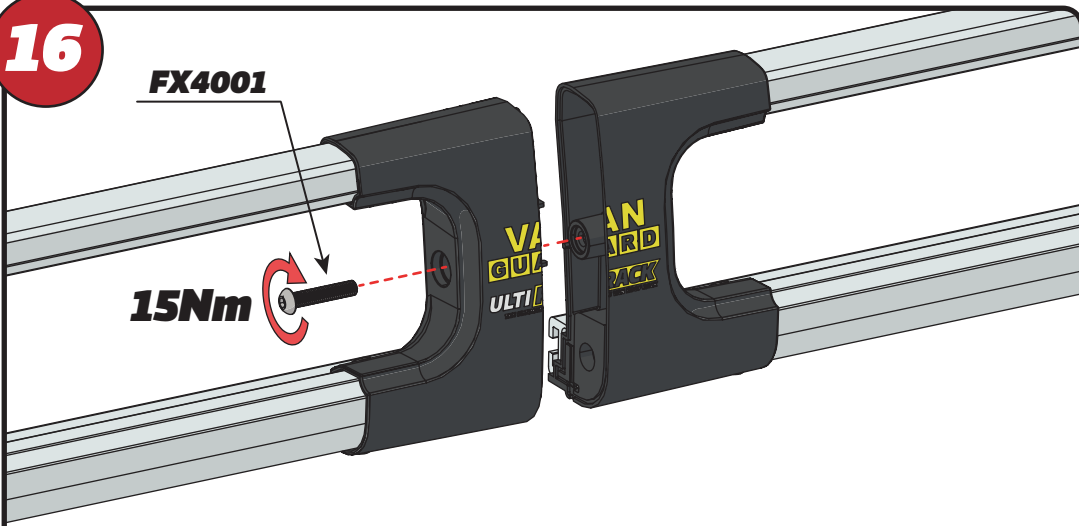

X2

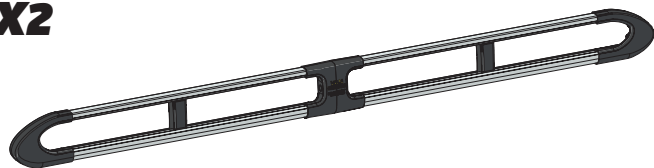

FX4008

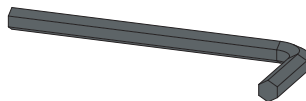

17

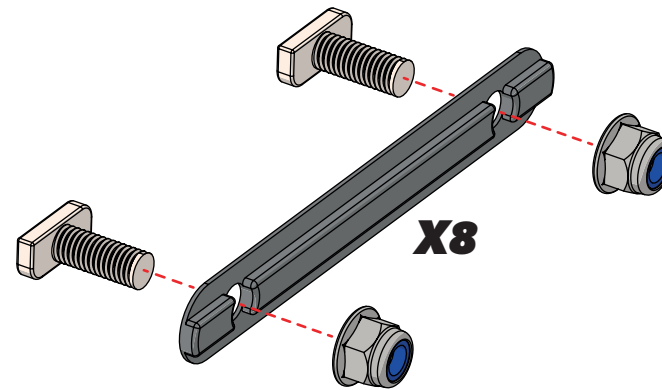

X8

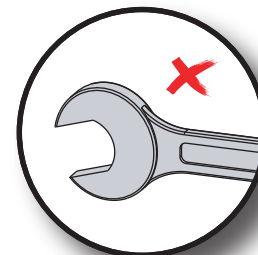
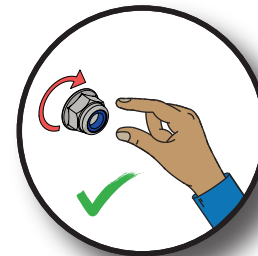

18

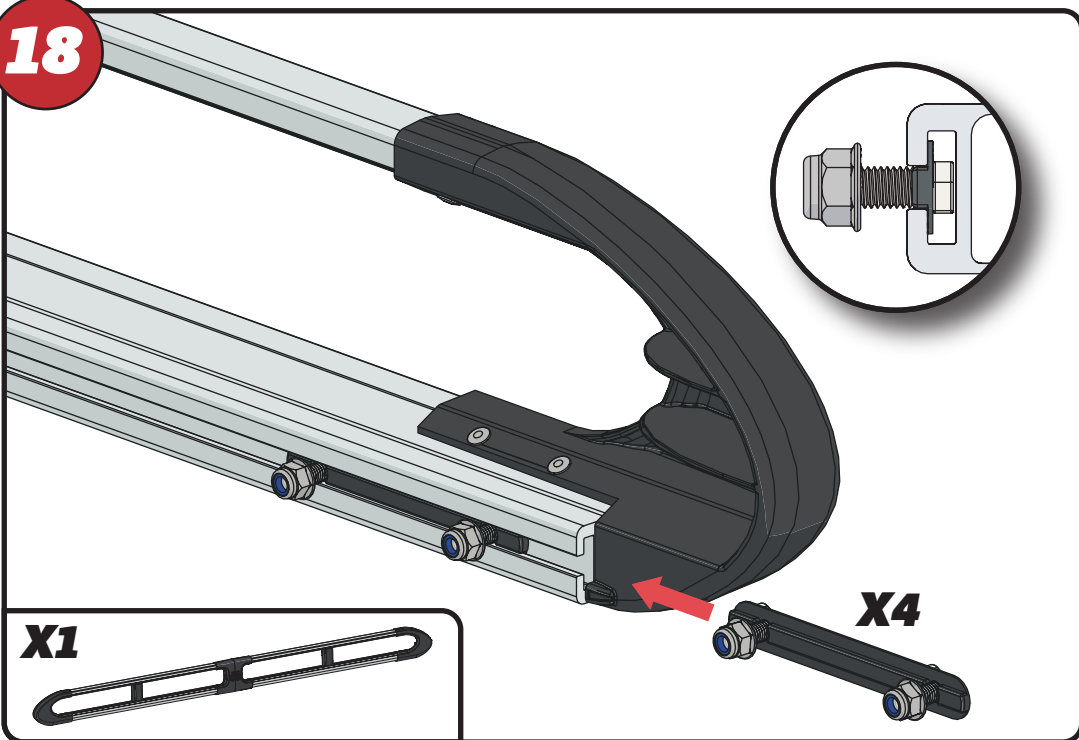

X1

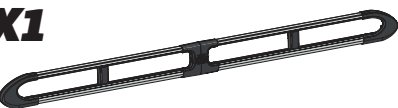

X4

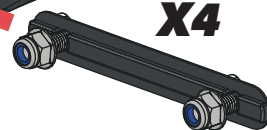

19

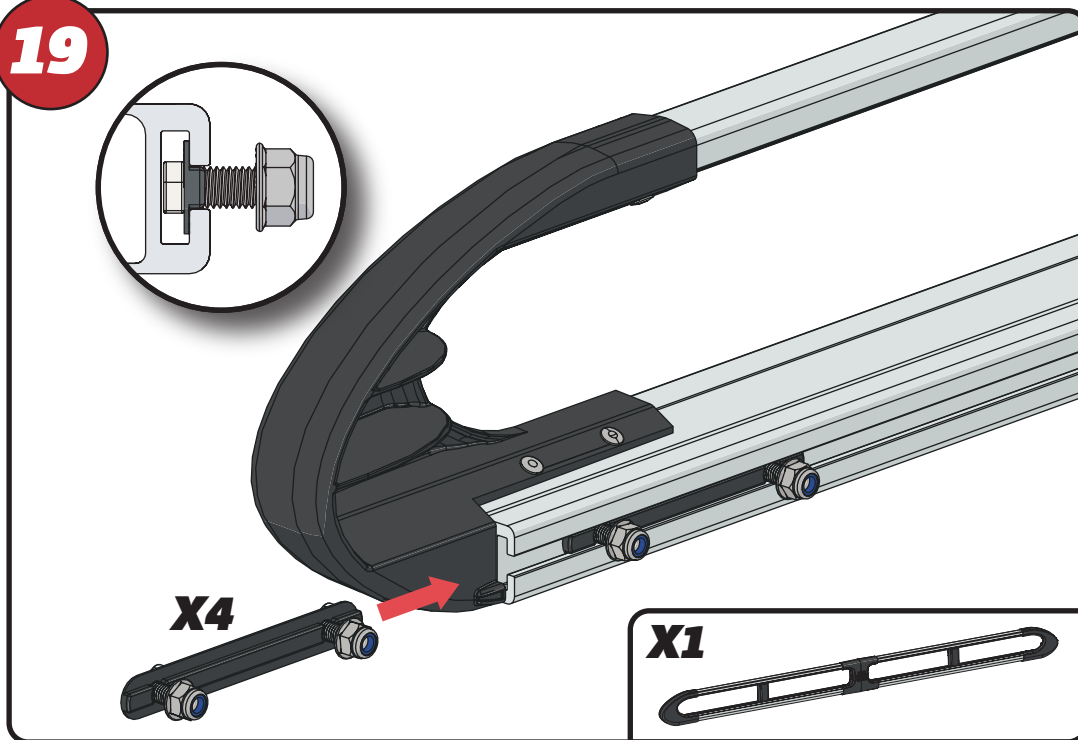

X4

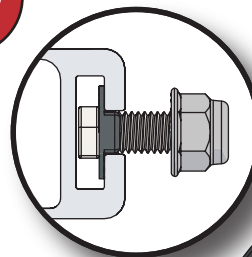

X1

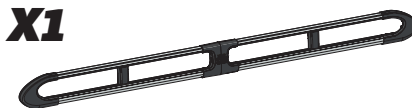

20

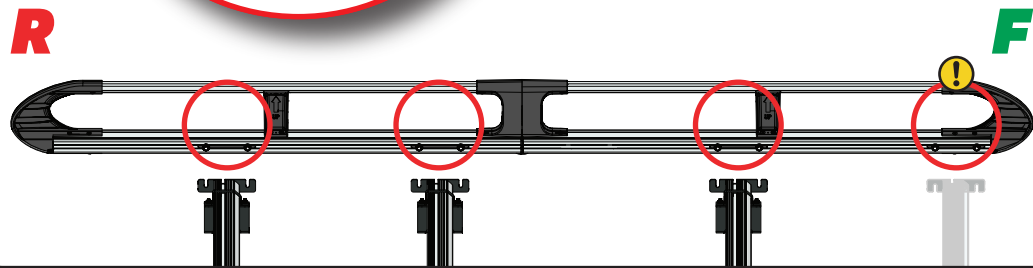
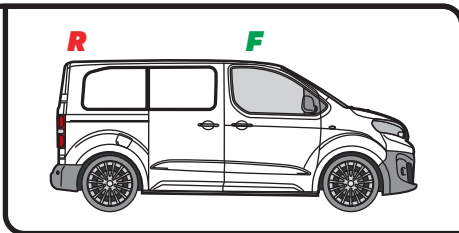
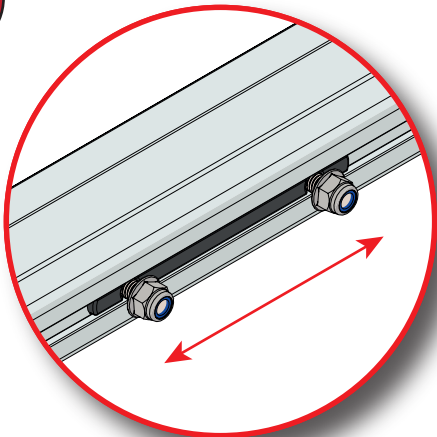

21

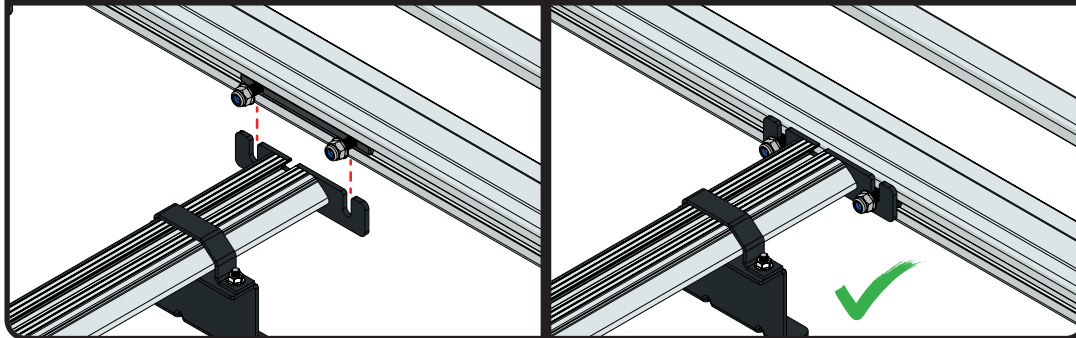
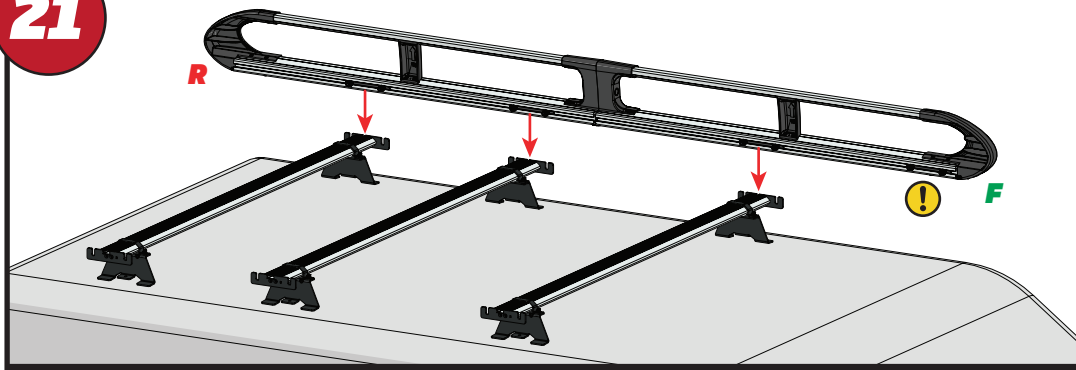

22

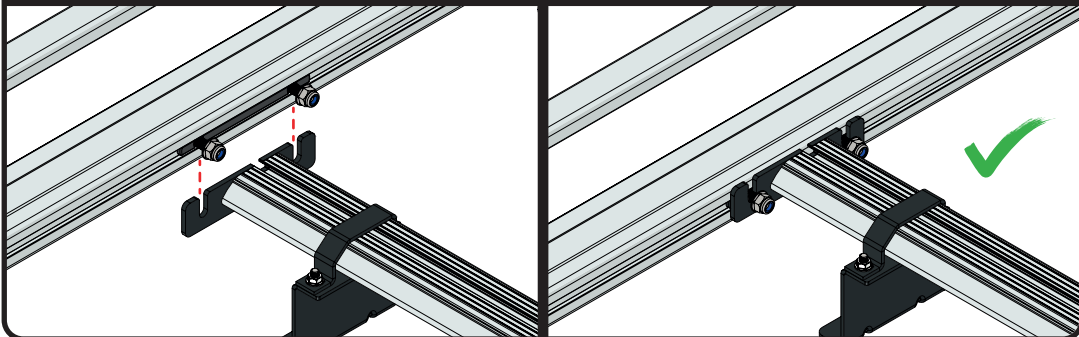
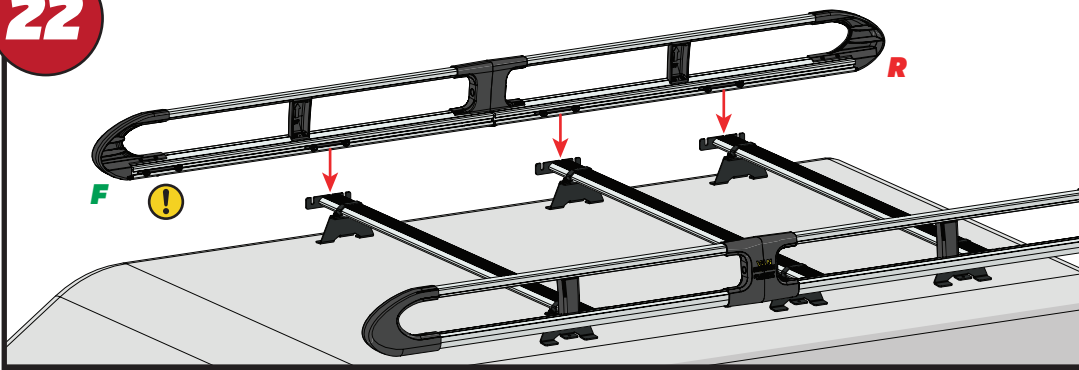

23

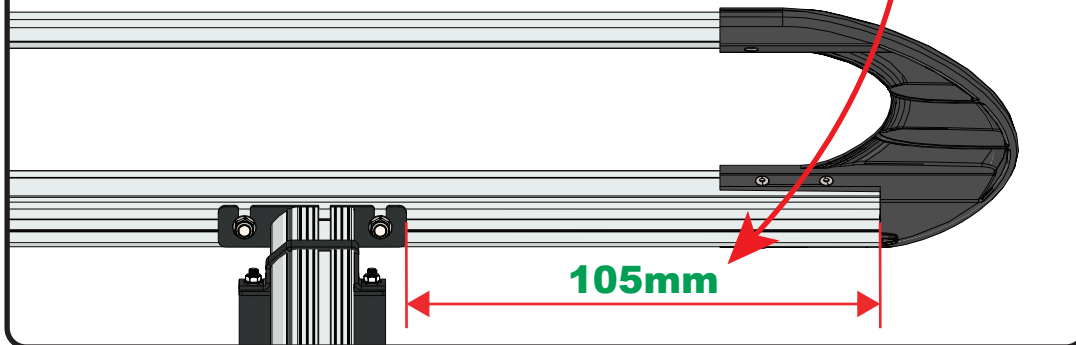
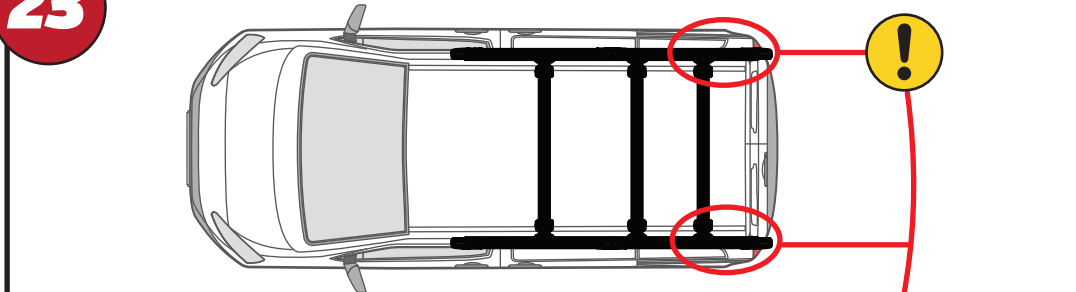

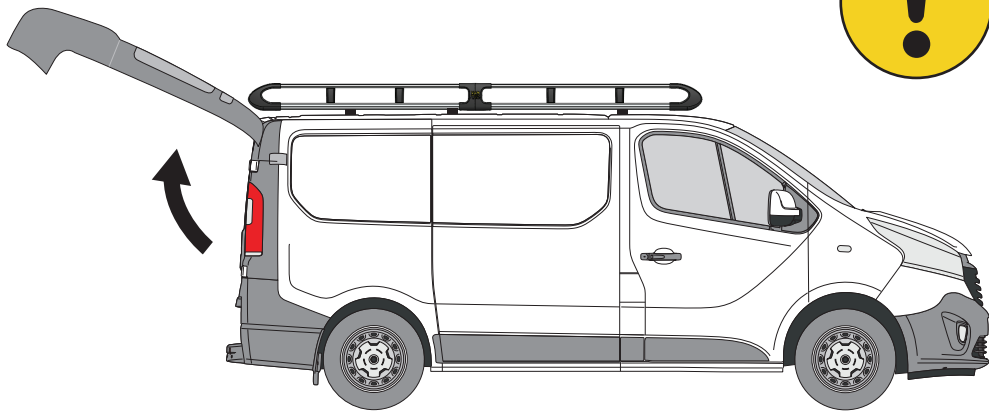
**24**

EN - CHECK TO ENSURE CLEARANCE FROM TAILGATE  
 DE - ÜBERPRÜFEN SIE DEN ABSTAND ZUR HECKKLAPPE  
 FR - VÉRIFIEZ LE DÉGAGEMENT PAR RAPPORT AU HAYON  
 NL - CONTROLEER OP VRIJHEID VAN DE ACHTERKLEP  
 ES - VERIFIQUE EL ESPACIO LIBRE CON LA PUERTA TRASERA  
 IT - CONTROLLARE LA DISTANZA DALLA PORTELLONE

SV - KONTROLLERA AVSTÅND TILL BAKLUCKAN  
 DA - KONTROLLER AFSTAND TIL BAGKLAPPEN  
 NO - KONTROLLER KLARERING FRA BAKLUKE  
 PL - SPRAWDŹ PRZEŚWIT OD TYLNEJ KLAPY  
 CS - ZKONTROLUJTE VZDÁLENOST OD ZADNÍCH DVEŘÍ

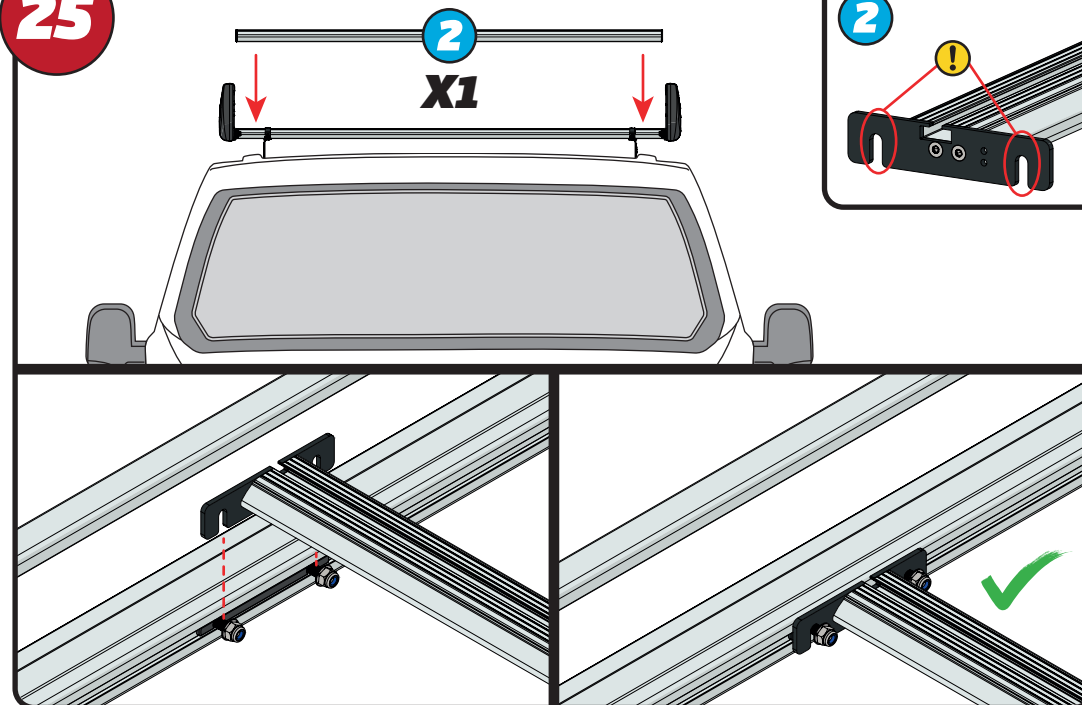
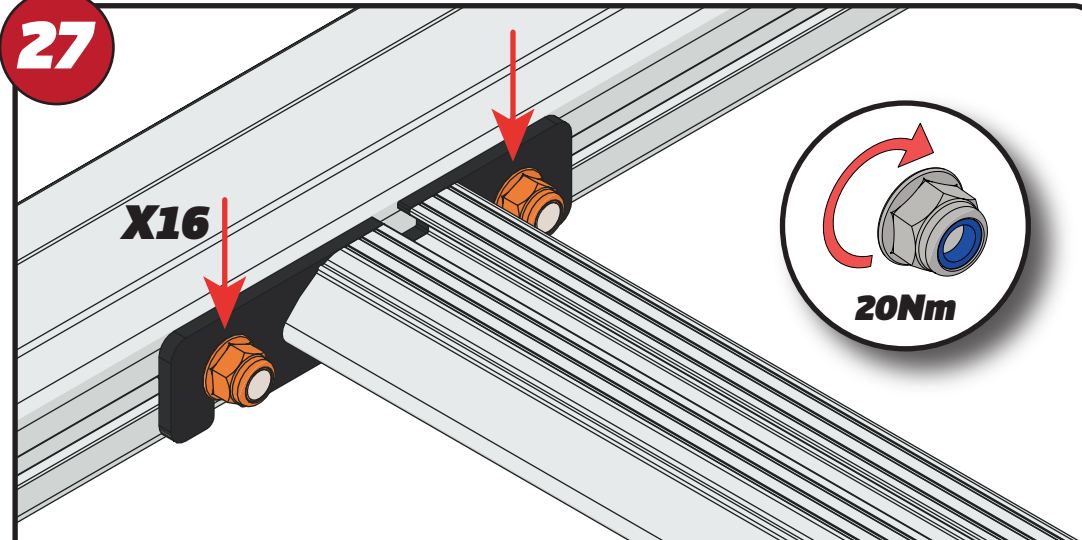
**25****27**

EN - TIGHTEN ALL OF THE CROSS BARS  
 DE - ALLE QUERSTANGEN FESTZIEHEN  
 FR - SERREZ TOUTES LES BARRES TRANSVERSALES  
 NL - DRAAI ALLE DWARSBALK VAN HET DAK AAN  
 ES - APRIETE TODAS LAS BARRAS TRANSVERSALES  
 IT - STRINGERE TUTTE LE BARRE TRASVERSALI

SV - SKRU UPP ALLA KORSSTANGAR  
 DA - SKRU ALLE TAGBØJLER OP  
 NO - SKRU OPP ALLE TVERRSTENGER  
 PL - DOKRĘCIĆ WSZYSTKIE POPRZECZKI  
 CS - VŠECHNY PŘÍČNÉ TYČE SEŠROUJTE

**26**

XXX =  
 PAGE 2 OF 14

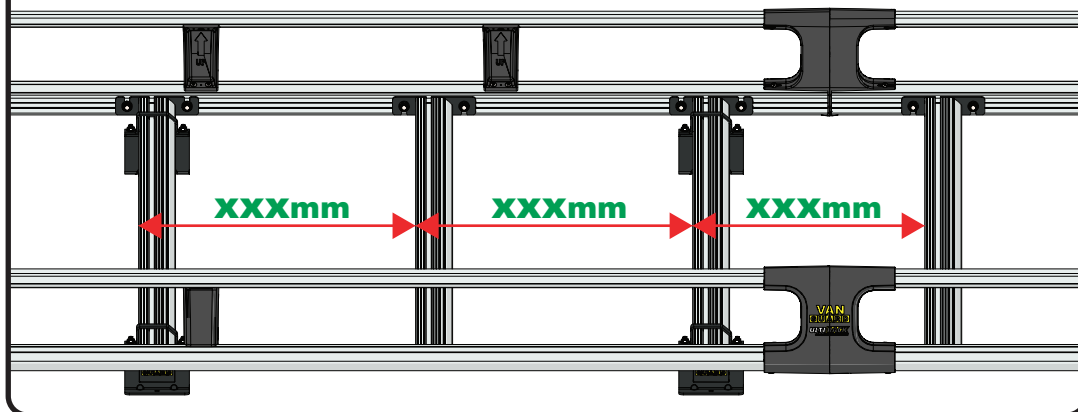
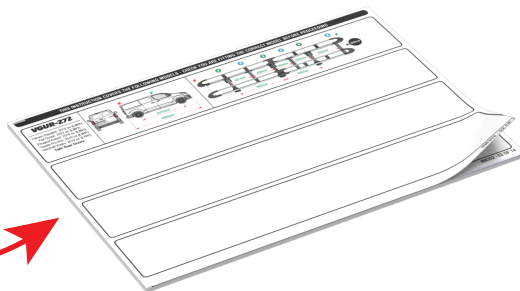

28

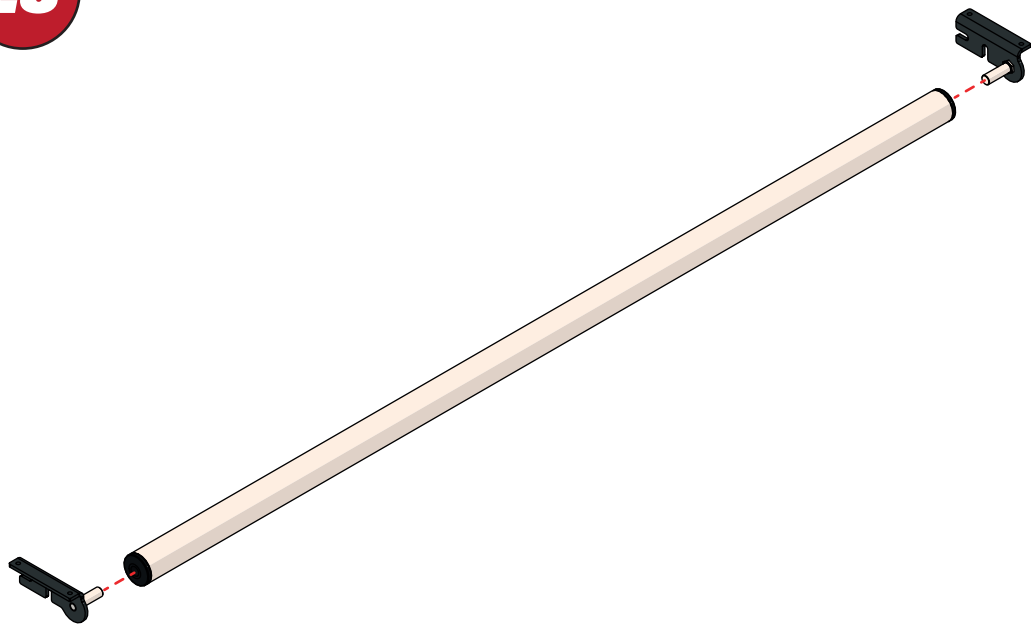

29

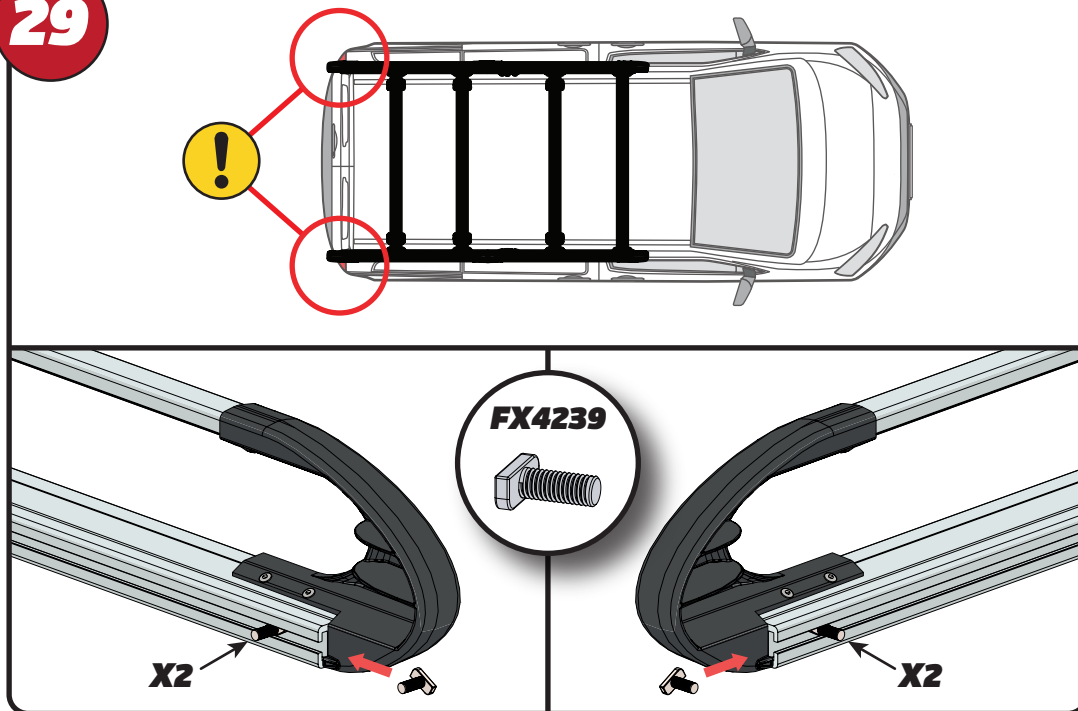

30

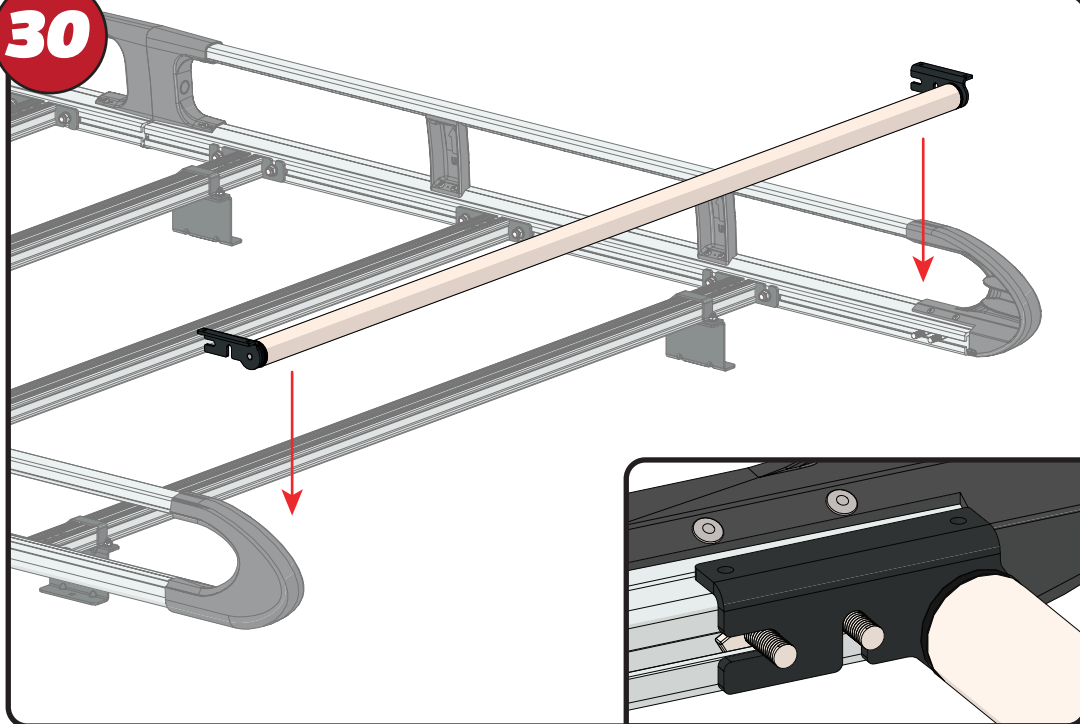

31

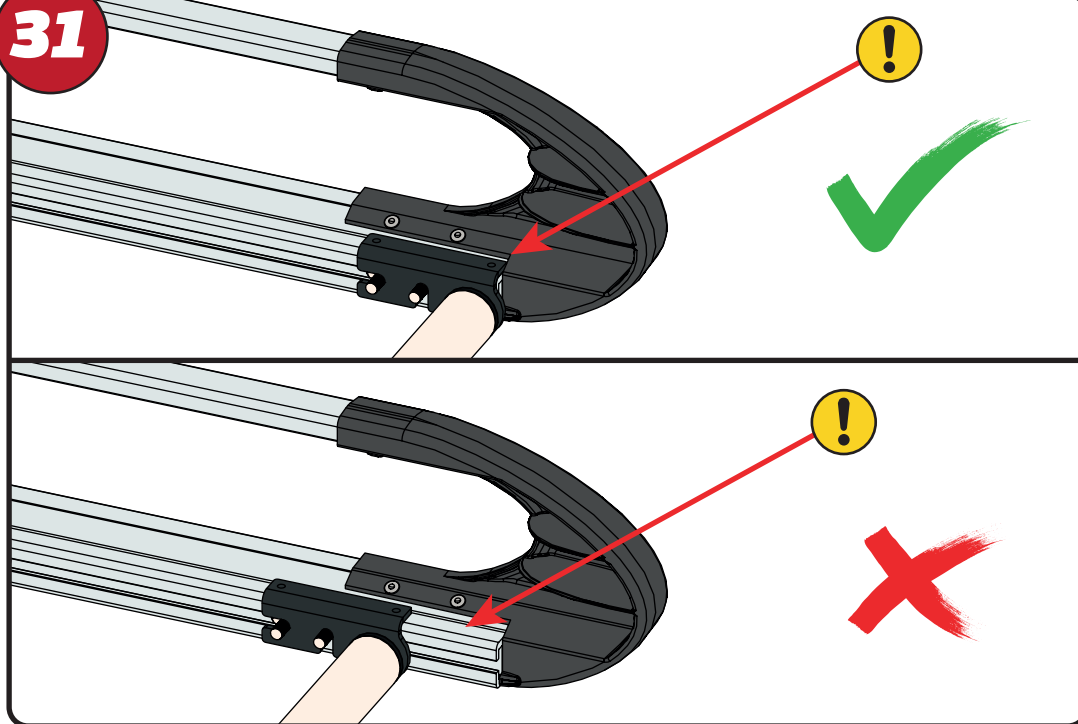

32

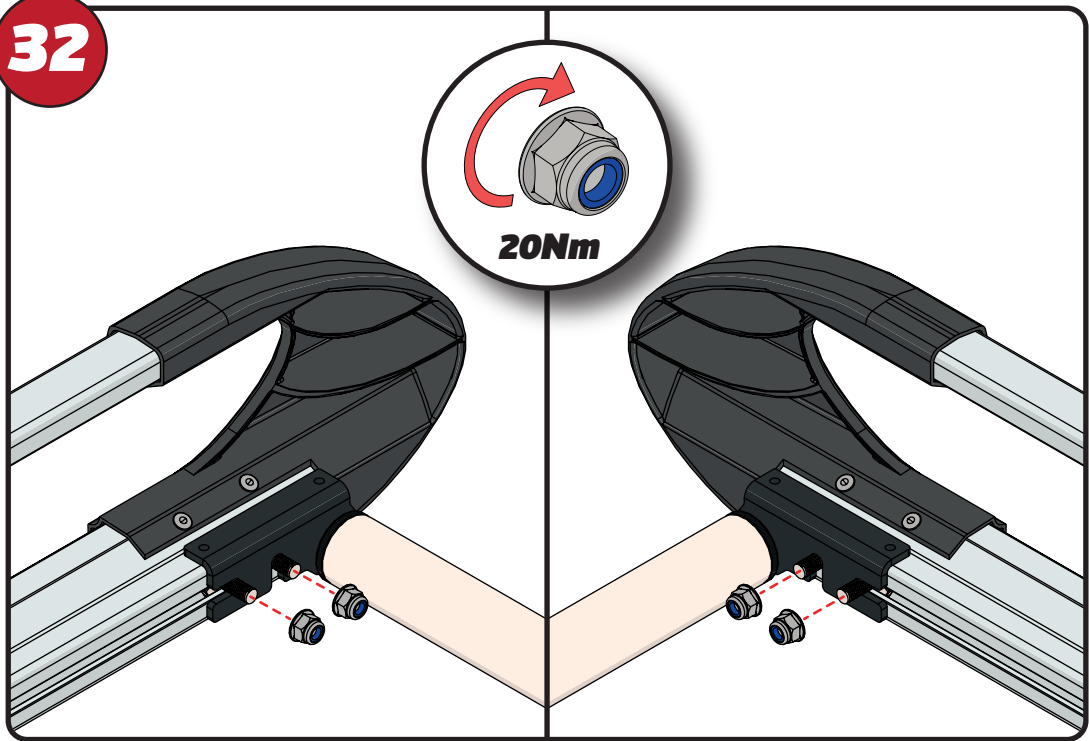

33

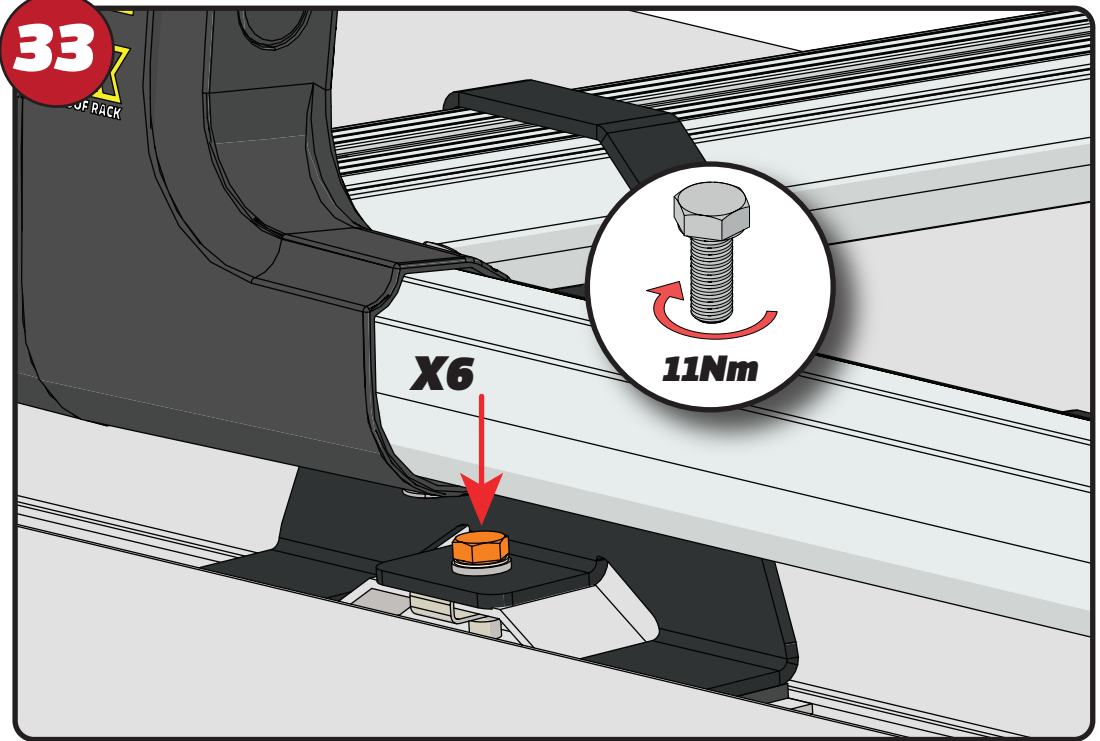

34

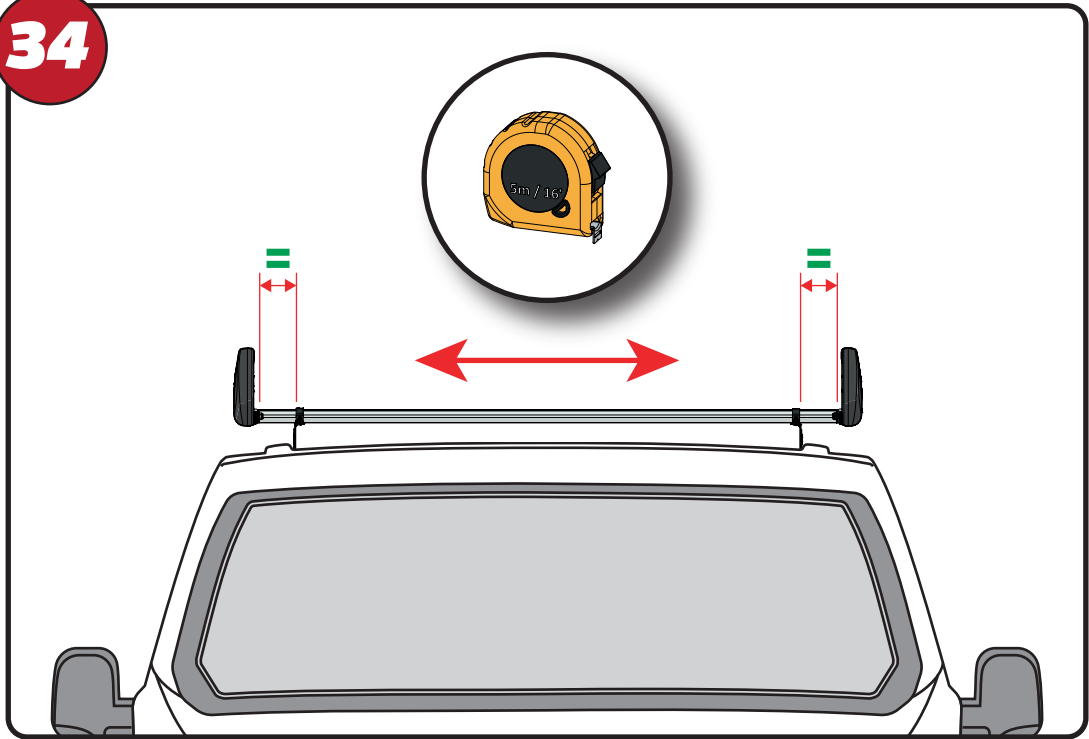

35

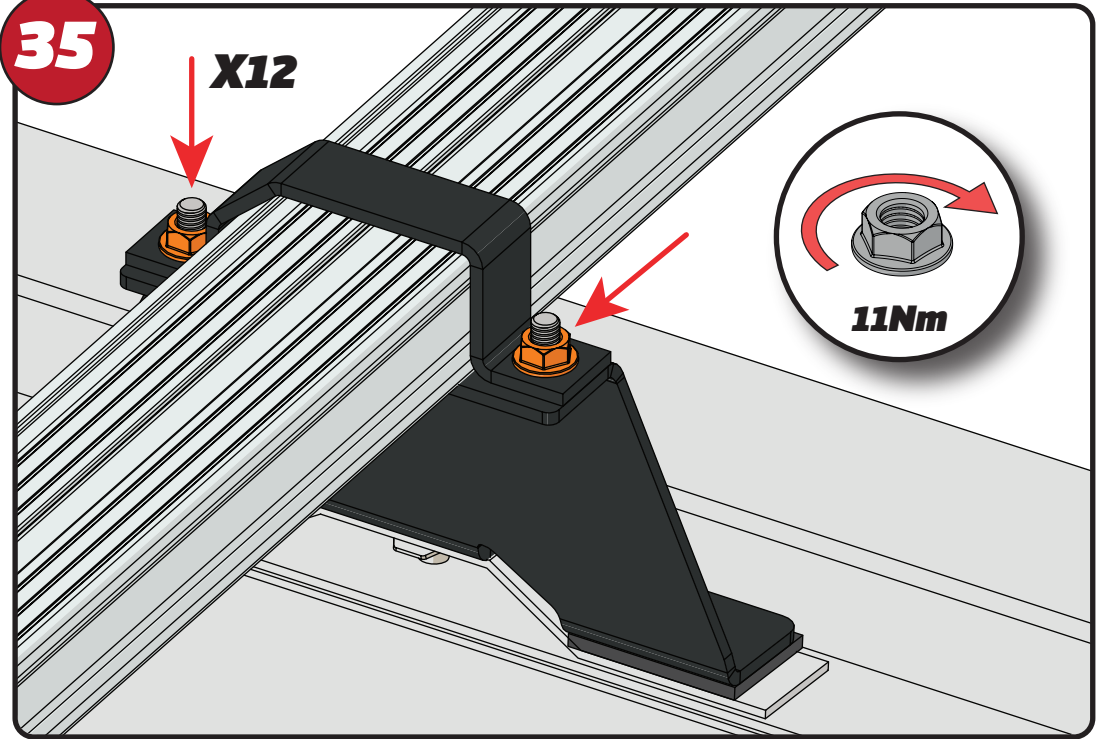

36



FX4241

X20

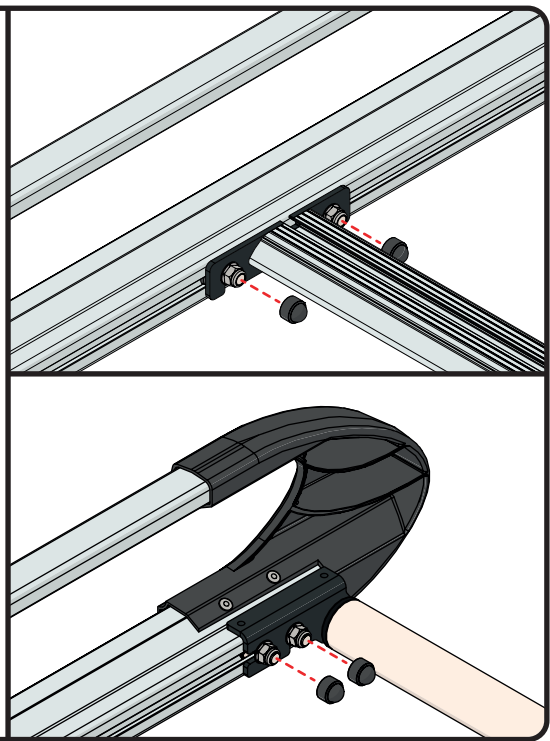

37



X6

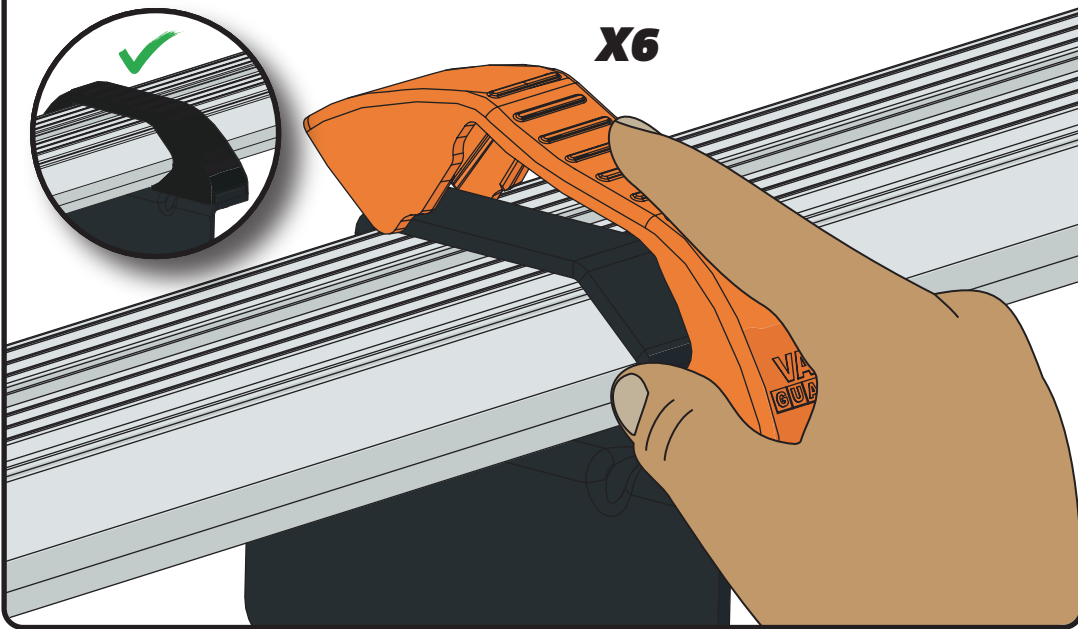

38

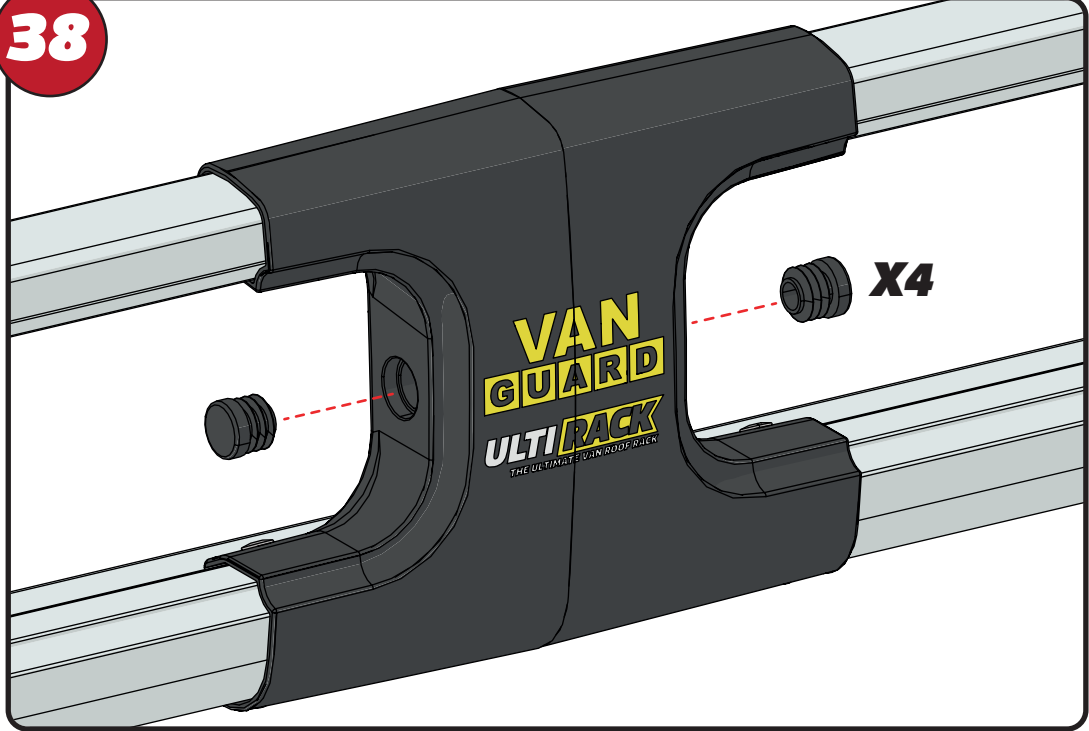

VAN GUARD  
ULTI RACK  
THE ULTIMATE VAN ROOF RACK

X4

39

