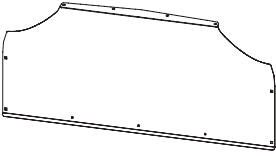
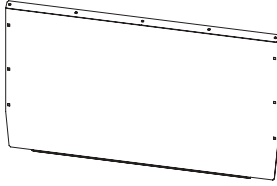
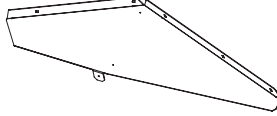
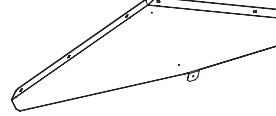
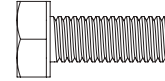
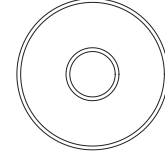
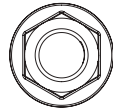
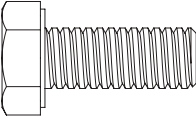
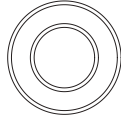
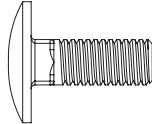
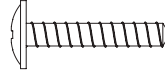

IN8175

Bulkhead - VG269S / VG269P

VG269S = ME0281 X1 VG269P = ME0282 X1 (TOP) 	ME0283 X1 (BOTTOM) 	ME0284 X1 (SIDE - RIGHT) 	ME0285 X1 (SIDE - LEFT) 	FX4012 X4 (M6X16) 	FX4013 X4 (M6) 	FX4016 X13 (M6) 
FX4018 X4 (M8X20) 	FX4020 X17 (M8) 	FX4042 X13 (M6X16) 	FX4091 X2 (No8 x 3/4") 			

CAUTION - IMPORTANT NOTES

1. You should note that it is the responsibility of the installer/s to ensure that when drilling holes in to your vehicle to take fixings, care must be taken to ensure that the fuel line, tyres, fuel tank, wiring loom, exhaust, bodywork and brake lines etc. are not damaged. Whilst every effort has been made to ensure our products can be safely fitted, changes to vehicles sometimes occur so it's always necessary to check before drilling.

If in doubt refer to the vehicle manufacturer's dealership.

2. When drilling, use as short a drill bit as possible to prevent damage to the vehicle. Use corrosion protection when drilling the vehicle.

3. Wear the appropriate protective equipment (safety glasses & gloves) while fitting this product.

4. Regularly inspect all fixings and parts. Any damaged or worn parts should be immediately removed the vehicle and replaced.

5. Retain instructions for future use. It is important that the end user receives this document.

TOOLS REQUIRED

SPANNER (10MM) X1



SPANNER (13MM) X1



PH SCREW DRIVER X1



DRILL (Ø3.2MM) X1

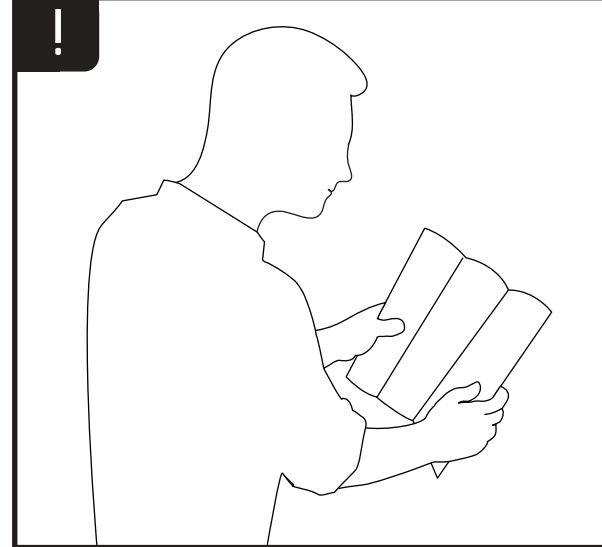

This FITTING INSTRUCTION is the property of VAN GUARD ACCESSORIES LTD. and must not be used for manufacturing purposes, copied nor communicated in any way to third parties without written permission from VAN GUARD ACCESSORIES LTD.
IN8175_B

Van Guard Accessories Ltd
Fair Oak Close, Exeter Airport Business Park,
Exeter, Devon, EX5 2UL
www.van-guard.co.uk

1 Please read the important notes on page 1 before fitting this product.

Remove the vehicles existing drivers seat tubular frame.



2 Assemble the top, bottom and sides together outside of the vehicle as shown below using M6x16 coach bolts (FX4042), M8 washers (FX4020) and M6 flange nuts (FX4016). Ensure that the top overlaps the bottom and the sides overlap both.

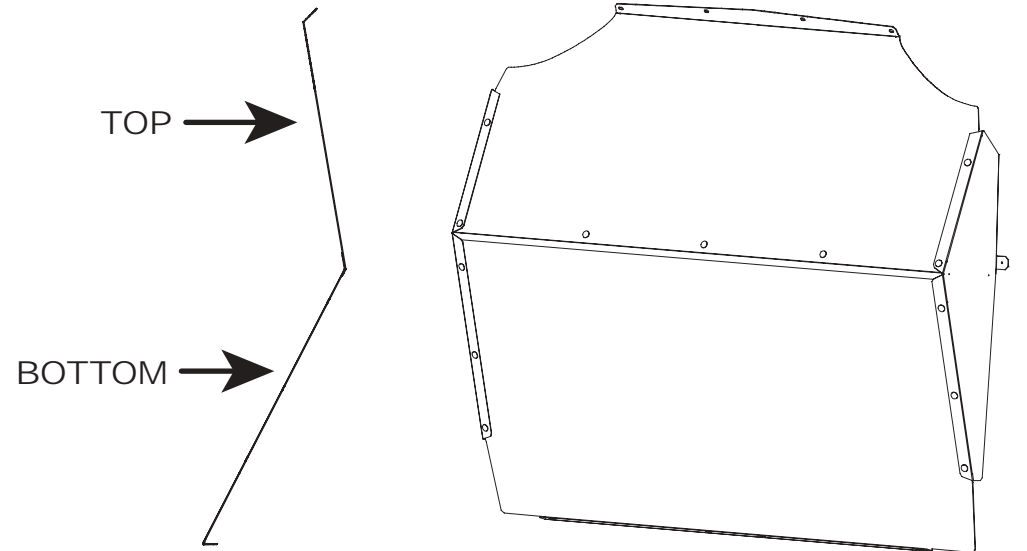

3 Carefully lift the complete bulkhead assembly (two man lift) into the vehicle.

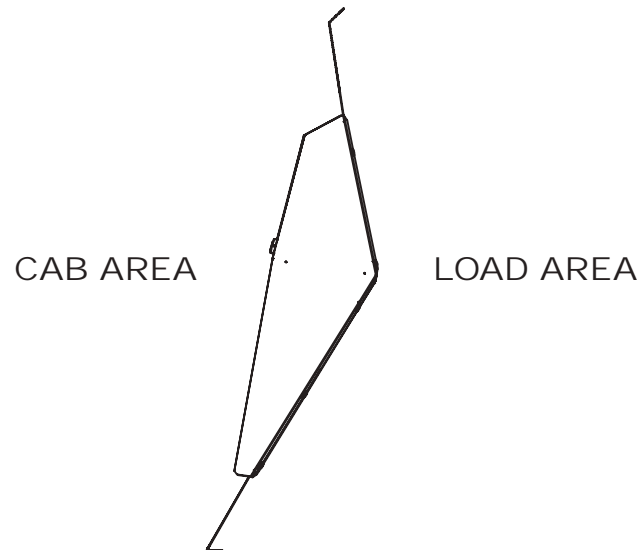

4 Secure the bulkhead to the vehicles existing threaded holes using M6x16 hex bolts (FX4012) and M6 washers (FX4013) along the top and M8x20 hex bolts (FX4018) and M8 washers (FX4020) along the bottom.

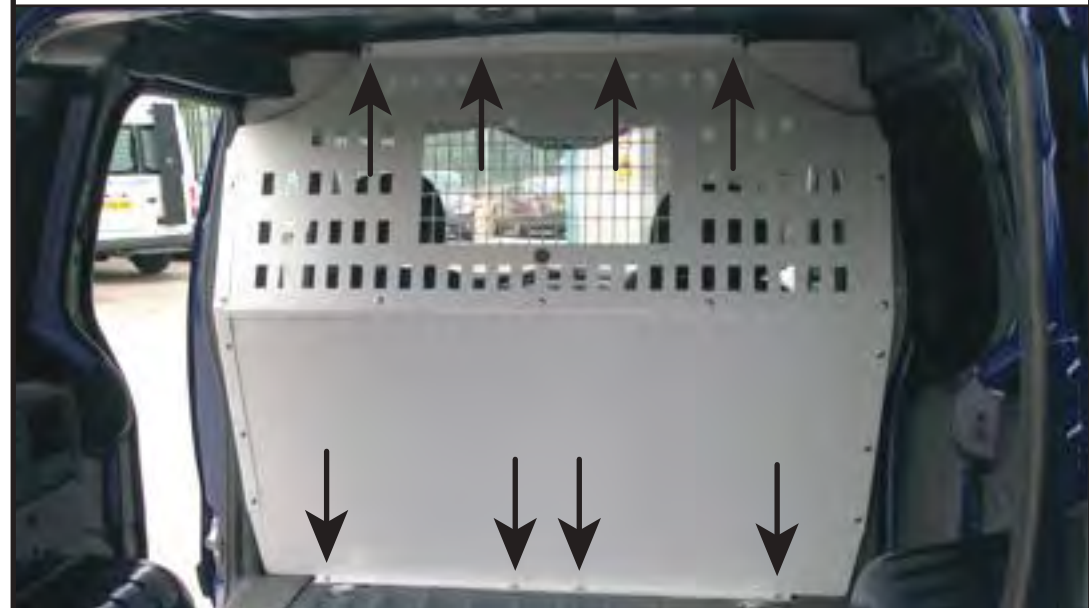

5 Carefully drill 3.2mm through the side tabs into the vehicles pillar and secure in place using No8x3/4" self-tap screws (FX4091).

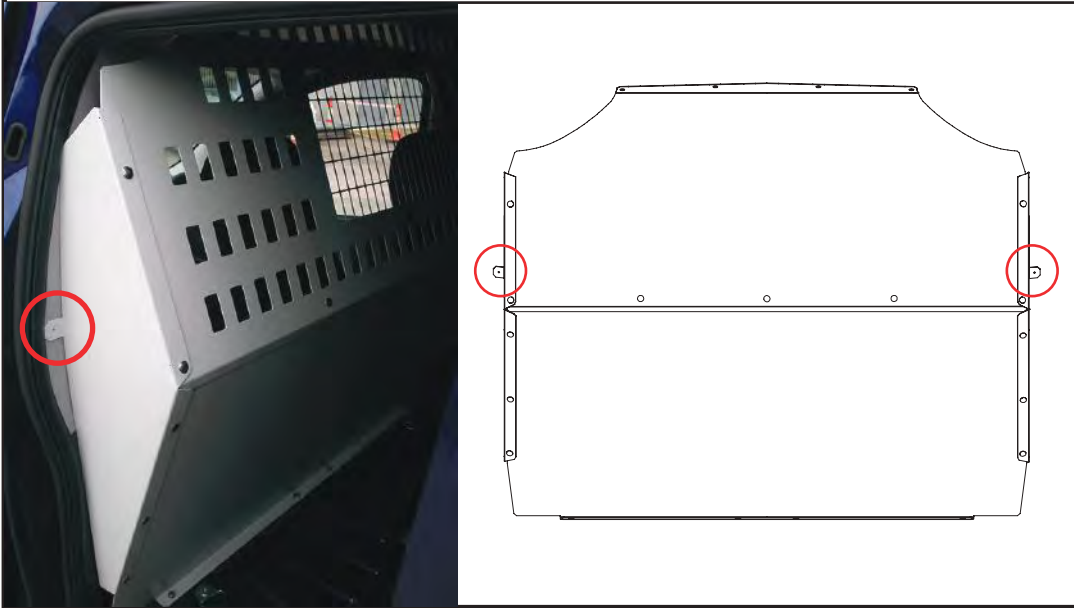

EXAMPLE IMAGE



EXAMPLE IMAGE

