

# IN8196

## Bulkhead - VG295S / VG295P

VG295S = ME0944 X1 VG295P = ME0945 X1 (TOP) 	AS3295 X1 (BOTTOM) 	AS3303 X1 (SIDE - RIGHT) 	AS3304 X1 (SIDE - LEFT) 	AS3296 X2 (FIXING PLATE - SIDE) 	AS3297 X1 (FIXING PLATE - MIDDLE) 	FX4010 X15 (M6) 
FX4012 X5 (M6X16) 	FX4013 X15 (M6) 	FX4060 X10 (M6X12) 	FX4090 X21 (No8 x 1/2") 			

**CAUTION - IMPORTANT NOTES**

1. You should note that it is the responsibility of the installer/s to ensure that when drilling holes in to your vehicle to take fixings, care must be taken to ensure that the fuel line, tyres, fuel tank, wiring loom, exhaust, bodywork and brake lines etc. are not damaged. Whilst every effort has been made to ensure our products can be safely fitted, changes to vehicles sometimes occur so it's always necessary to check before drilling.

If in doubt refer to the vehicle manufacturer's dealership.

2. When drilling, use as short a drill bit as possible to prevent damage to the vehicle. Use corrosion protection when drilling the vehicle.

3. Wear the appropriate protective equipment (safety glasses & gloves) while fitting this product.

4. Regularly inspect all fixings and parts. Any damaged or worn parts should be immediately removed the vehicle and replaced.

5. Retain instructions for future use. It is important that the end user receives this document.

**TOOLS REQUIRED**

SPANNER (10MM) X1



PH SCREW DRIVER X1



DRILL (Ø3.2MM) X1

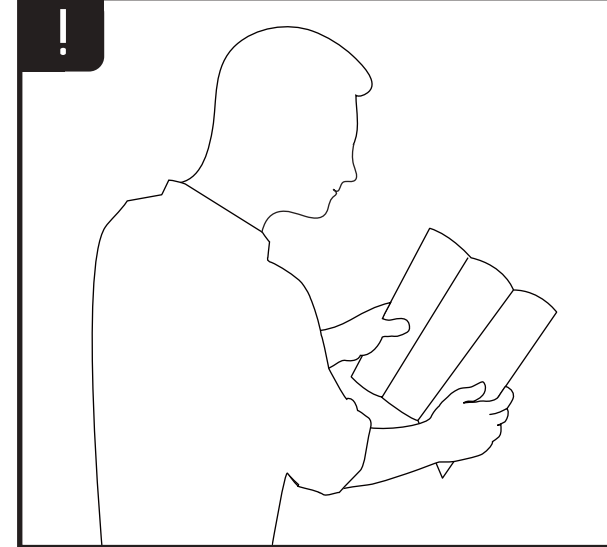
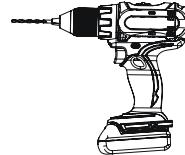

This FITTING INSTRUCTION is the property of VAN GUARD ACCESSORIES LTD. and must not be used for manufacturing purposes, copied nor communicated in any way to third parties without written permission from VAN GUARD ACCESSORIES LTD.

IN8196\_B

Van Guard Accessories Ltd  
 Fair Oak Close, Exeter Airport Business Park,  
 Exeter, Devon, EX5 2JL  
[www.van-guard.co.uk](http://www.van-guard.co.uk)

**1** Please read the important notes on page 1 before fitting this product.

Position the bottom bulkhead into the vehicle with the flange along the top edge facing into the cab area. Once happy with the position carefully drill 3.2mm through the locations shown below and secure using No8x1/2" self-tap screws (FX4090).

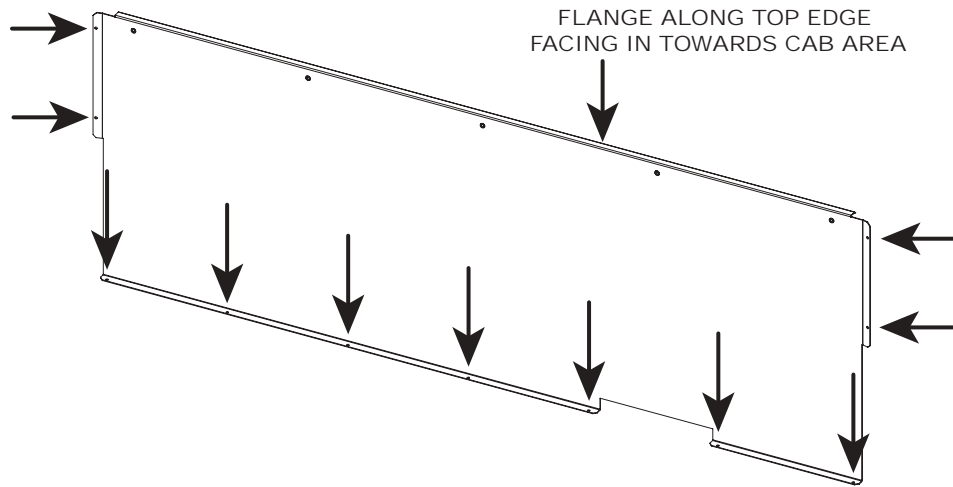

**2** Loosely secure the fixing plates to the top bulkhead by bolting into the threaded inserts using M6x12 hex bolts (FX4060), M6 shakeproof washers (FX4010) and M6 washers (FX4013).

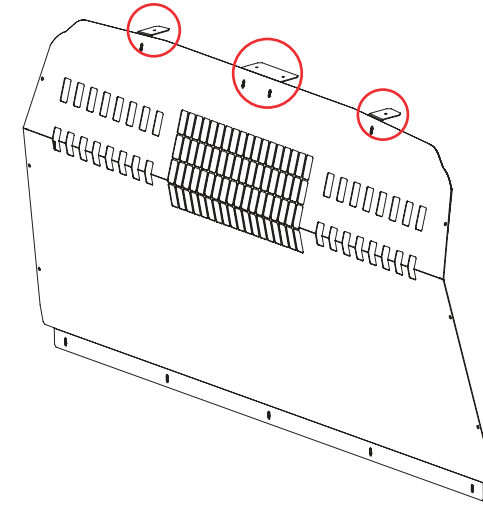

**3** Loosely secure the sides to the top bulkhead by bolting into the threaded inserts using M6x12 hex bolts (FX4060), M6 shakeproof washers (FX4010) and M6 washers (FX4013).

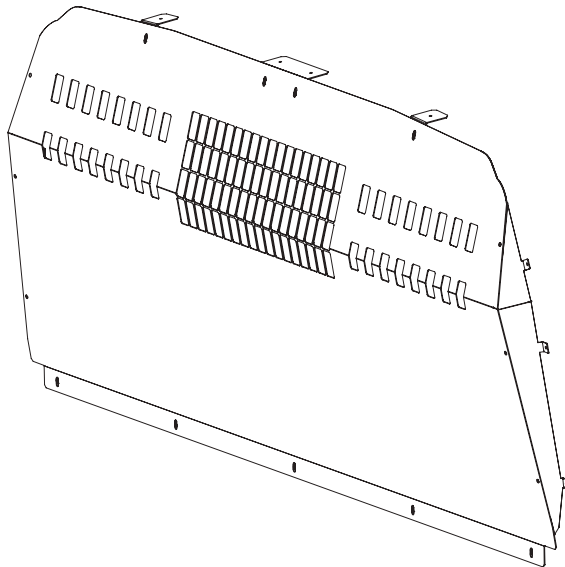

**4** Lift the top bulkhead into the vehicle and secure to the bottom by bolting into the five threaded inserts with M6x16 hex bolts (FX4012), M6 shakeproof washers (FX4010) and M6 washers (FX4013). Ensure that the top overlaps the bottom.

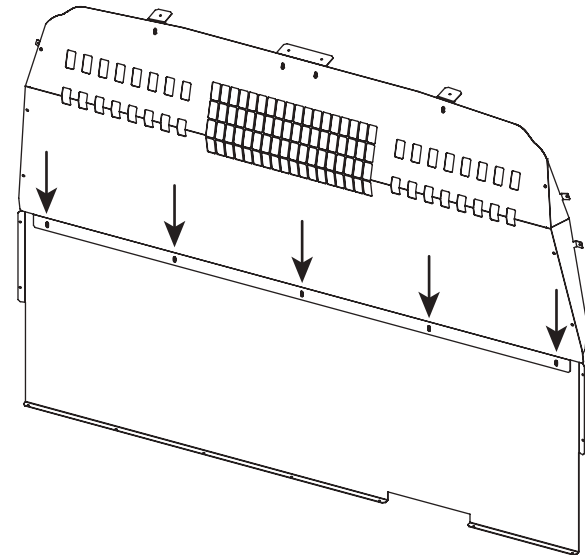

**5** Once happy with the position of the bulkhead carefully drill 3.2mm through the side tab fixing positions and secure using No8x1/2" self-tap screws (FX4090).

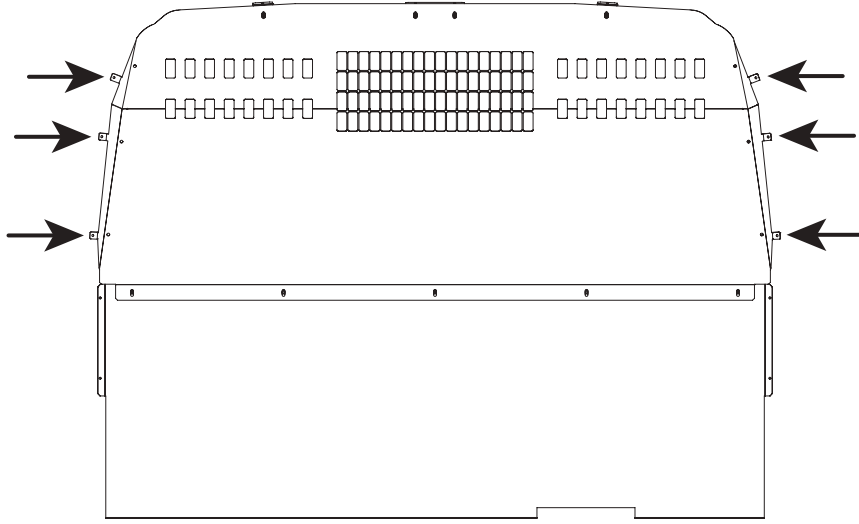

**6** Position and tighten the fixing plates upto the trim covered roof support. Once happy with the position carefully drill 3.2mm through the fixing positions on the brackets and secure using No8x1/2" self-tap screws (FX4090).

Once the plates have been secured, tighten all of the remaining fixings.



**EXAMPLE IMAGE**



**EXAMPLE IMAGE**

