

IN8176

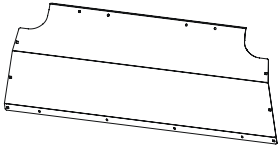
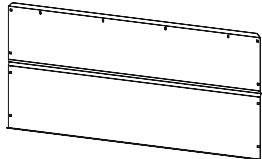
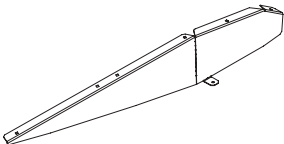
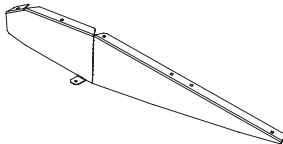
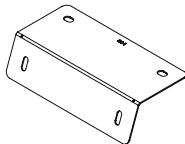
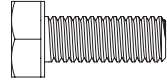
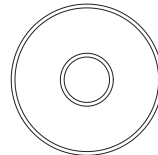
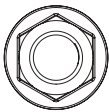
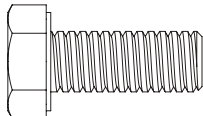
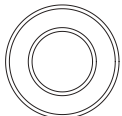
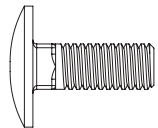
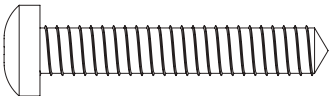
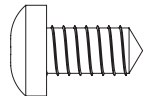

Bulkhead - VG273 / VG298

<p>VG273S / VG298S = AS3291 X1 VG273P / VG298P = AS3292 X1 (TOP)</p> 	<p>VG273S / VG273P = ME0310 X1 VG298S / VG298P = AS3298 X1 (BOTTOM)</p> 	<p>ME0312 X1 (SIDE - RIGHT)</p> 	<p>ME0313 X1 (SIDE - LEFT)</p> 	<p>ME0311 X1 (FIXING PLATE)</p> 	<p>FX4012 X2 (M6X16)</p> 	<p>FX4013 X2 (M6)</p> 
<p>FX4016 X16 (M6)</p> 	<p>FX4018 X2 (M8X20)</p> 	<p>FX4020 X18 (M8)</p> 	<p>FX4042 X16 (M6X16)</p> 	<p>FX4086 X2 (No14 x 1.5")</p> 		<p>FX4087 X4 (No14 x 1/2")</p> 

CAUTION - IMPORTANT NOTES

1. You should note that it is the responsibility of the installer/s to ensure that when drilling holes in to your vehicle to take fixings, care must be taken to ensure that the fuel line, tyres, fuel tank, wiring loom, exhaust, bodywork and brake lines etc. are not damaged. Whilst every effort has been made to ensure our products can be safely fitted, changes to vehicles sometimes occur so it's always necessary to check before drilling.
If in doubt refer to the vehicle manufacturer's dealership.
2. When drilling, use as short a drill bit as possible to prevent damage to the vehicle. Use corrosion protection when drilling the vehicle.
3. Wear the appropriate protective equipment (safety glasses & gloves) while fitting this product.
4. Regularly inspect all fixings and parts. Any damaged or worn parts should be immediately removed the vehicle and replaced.
5. Retain instructions for future use. It is important that the end user receives this document.

TOOLS REQUIRED

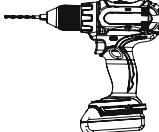
- SPANNER (10MM) X1

- SPANNER (13MM) X1

- PH SCREW DRIVER X1

- DRILL (Ø4.5MM) X1



This FITTING INSTRUCTION is the property of VAN GUARD ACCESSORIES LTD. and must not be used for manufacturing purposes, copied nor communicated in any way to third parties without written permission from VAN GUARD ACCESSORIES LTD.
IN8176_B

Van Guard Accessories Ltd
Fair Oak Close, Exeter Airport Business Park,
Exeter, Devon, EX5 2UL
www.van-guard.co.uk

1 Please read the important notes on page 1 before fitting this product. Do not remove the drivers seat existing tubular frame, this frame stays in place and the bulkhead has been designed to fit behind it.



2 Assemble the top, bottom and sides together outside of the vehicle as shown below using M6x16 coach bolts (FX4042), M8 washers (FX4020) and M6 flange nuts (FX4016). Ensure that the top overlaps the bottom and the sides overlap both.

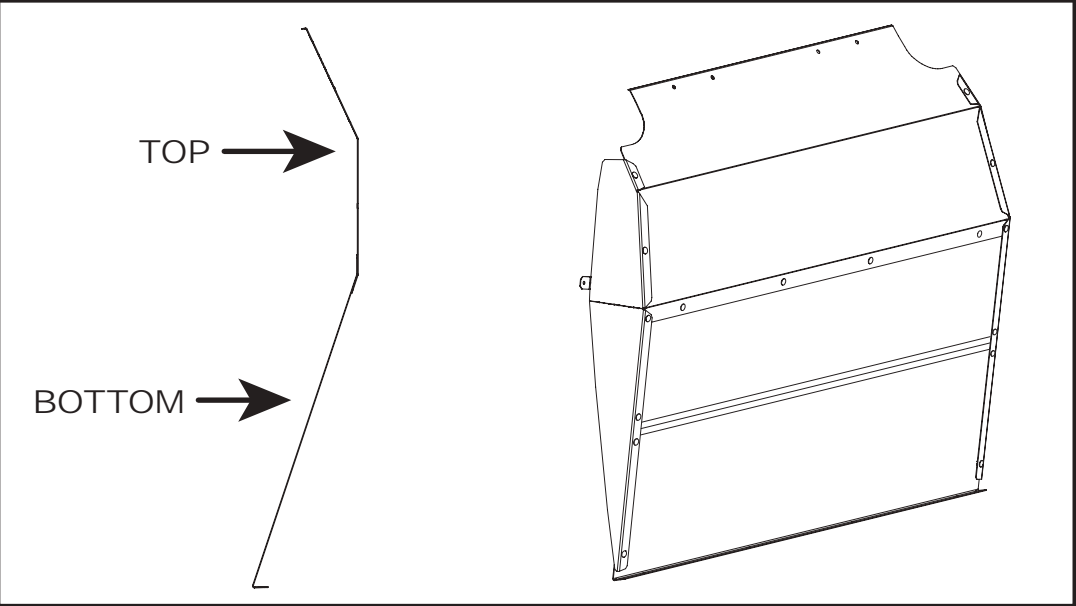

3 Loosely secure the fixing plate to the top of the bulkhead in the position shown below by bolting into the threaded inserts on the top bulkhead using M6x16 hex bolts (FX4012) and M6 washers (FX4013).

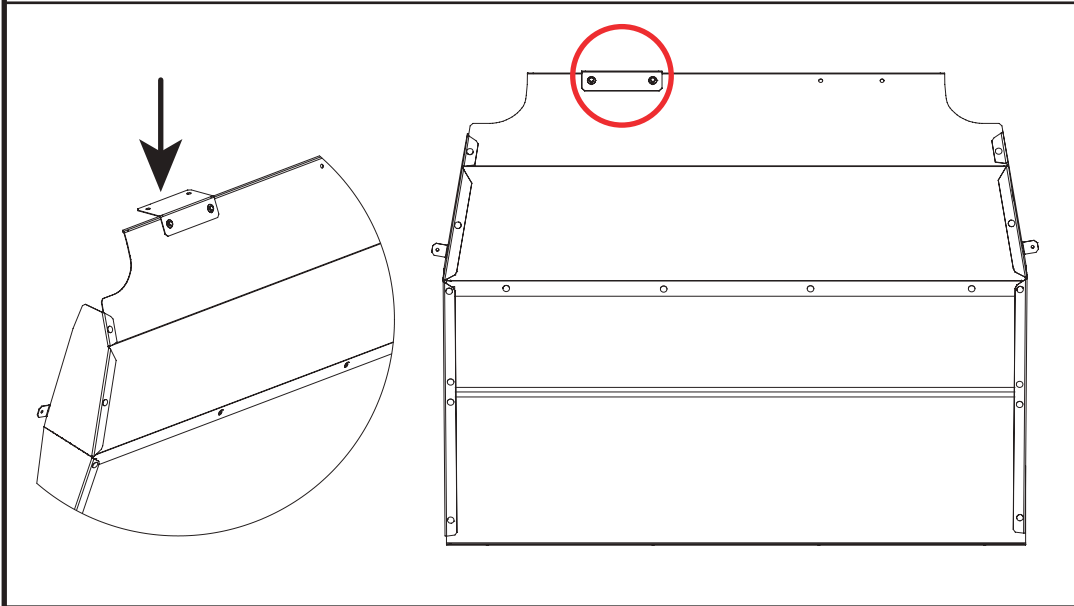

4 Lift the bulkhead into the vehicle (two man lift) with the bottom return facing into the load area.

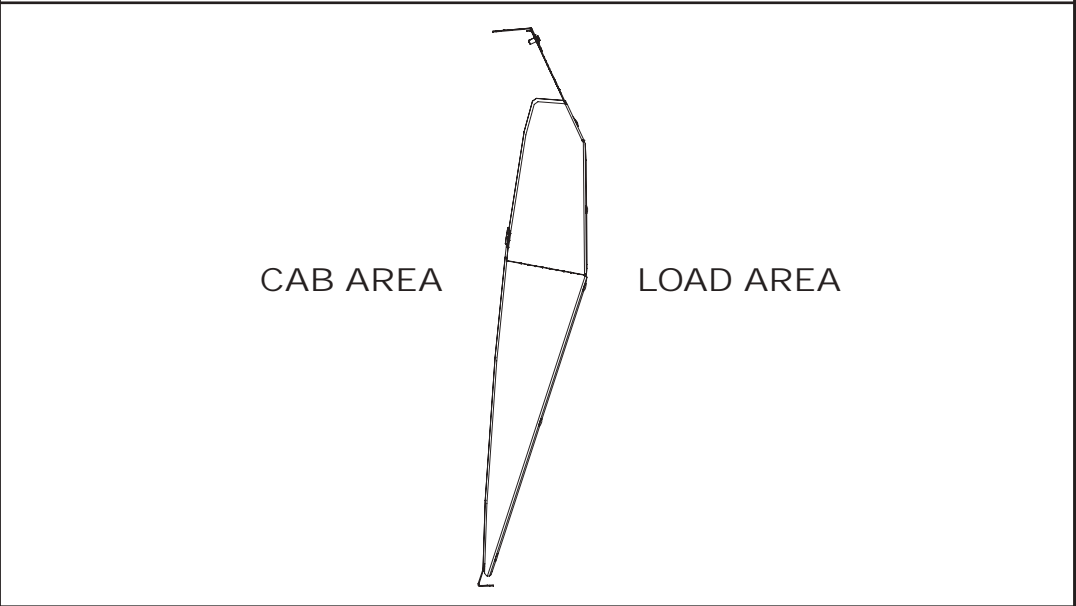

5 Remove the two M8 plugs from the vehicle to reveal the vehicles fixing points. Loosely secure the bulkheads fixing plate to the vehicles fixing points using M8x20 hex bolts (FX4018) and M8 washers (FX4020).



6 Once happy with the position of the bulkhead carefully drill 4.5mm through the four holes on the bottom return and secure using No14x1/2" self-tap screws (FX4087).

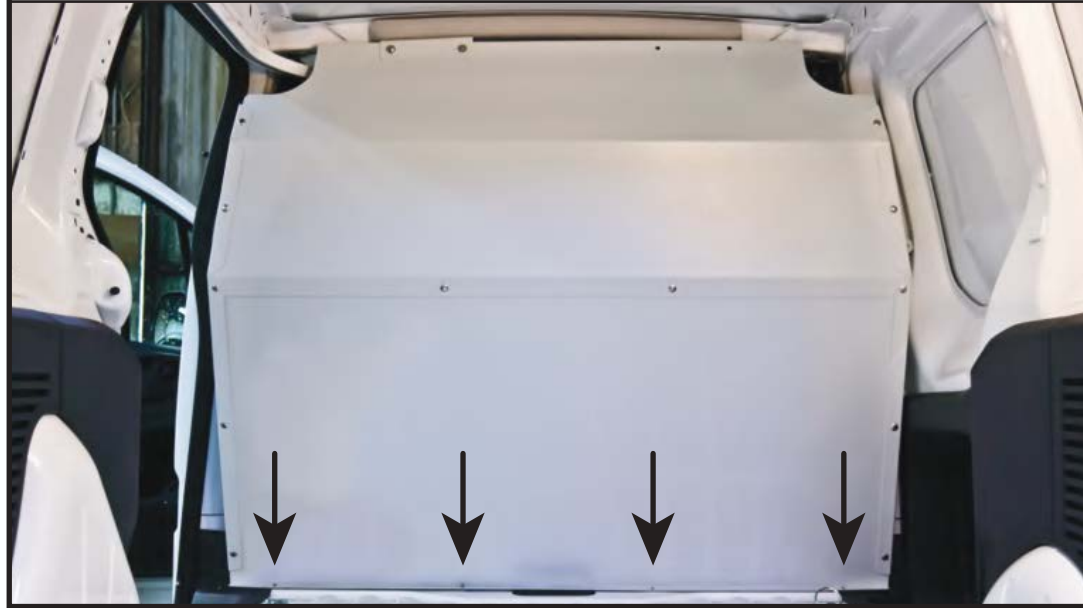

7 Carefully drill 4.5mm through the hole on the side tab (one per side) and secure to the door pillar using No14x1.5" self-tap screws (FX4086).

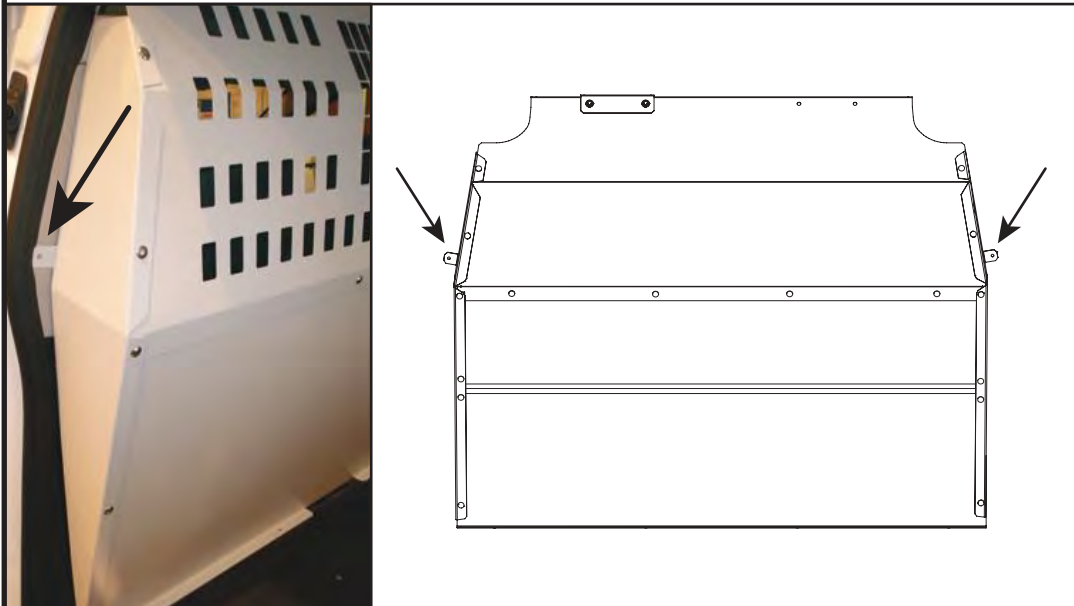

8 Lastly tighten all fixing plate bolts.

