

IN8139

ULTI Bars - X3

FX4010 X6 (M6) 	FX4013 X6 (M6) 	FX4014 X6 (RUBBER) 	FX4016 X12 (M6) 	FX4021 X6 (M6X25) 	FX4042 X12 (M6X16) 	MA6023 X6 	MA6065 X6
MEO203 X6 	ME0791 X1 		ME0792 X1 		AS3188 X3 		

TOOLS REQUIRED

10MM X 1

!

GB. Tested to 80kg per bar. Maximum load is in accordance with the vehicle manufacturer's load bearing capacity (refer to the vehicle handbook). **Do not exceed this limit.**

FR. Testé à 80 kg par barre. La charge maximale doit être conforme à la capacité de charge du constructeur de véhicule (veuillez- vous référer au livret du véhicule). **Ne dépassez pas cette limite.**

DE. Geprüft bis 80kg pro bar. Die Maximallast steht im Einklang mit der angegebenen Ladekapazität des Fahrzeugherstellers (diese finden Sie im Fahrzeughandbuch). **Die Maximallast darf nicht überschritten werden.**

DK. Testet til 80 kg pr. bar. Maksimal lasteevne afhænger af varevognproducents angivelser i varevognens håndbog. **Overskrid ikke denne grænse.**

This FITTING INSTRUCTION is the property of VAN GUARD ACCESSORIES LTD. and must not be used for manufacturing purposes, copied nor communicated in any way to third parties without written permission from VAN GUARD ACCESSORIES LTD.

Van Guard Accessories Ltd
 Fair Oak Close, Exeter Airport Business Park,
 Exeter, Devon, EX5 2UL
www.van-guard.co.uk

VG313-3

Vehicle:
Ford Transit Courier: 2014 on
Wheel Base: Standard (L1)
Roof Height: Standard (H1)
Rear Doors: Twin / Tailgate

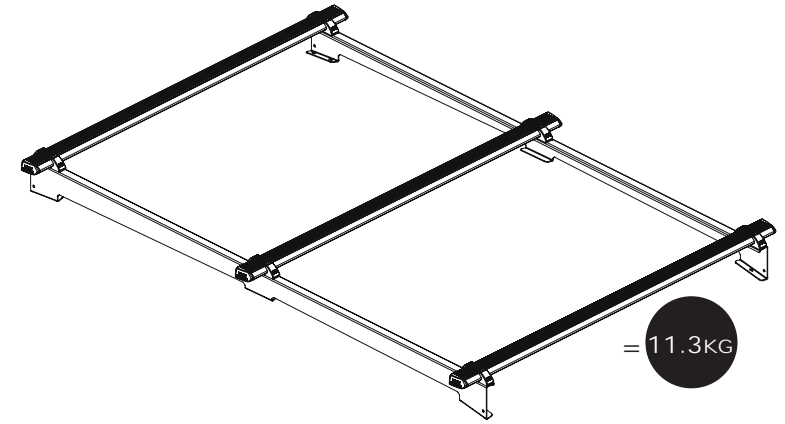
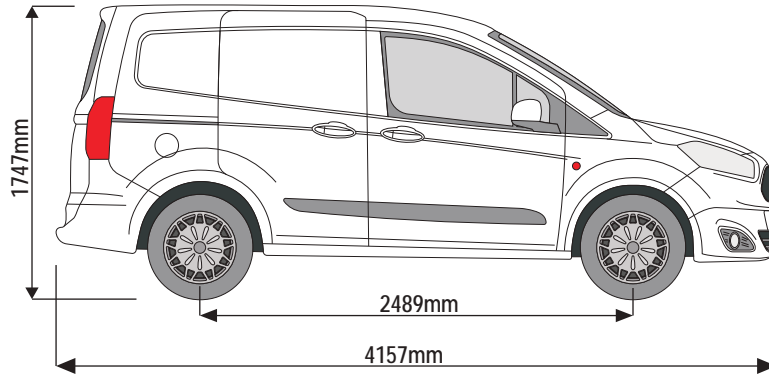

1 The side rails are handed to suit both sides of the vehicle. The front (F) foot of the side rail has 1 fixing slot and the rear (R) foot has 2 fixing slots.

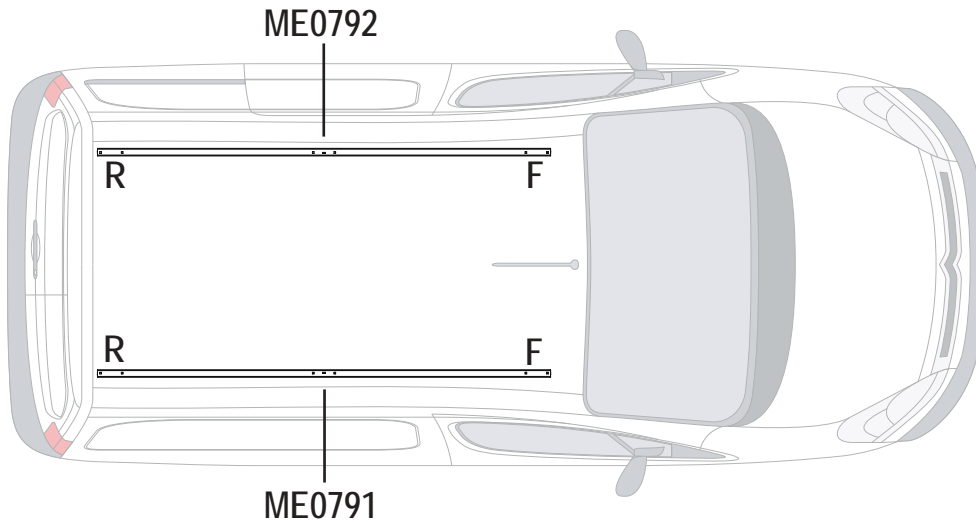

ME0791

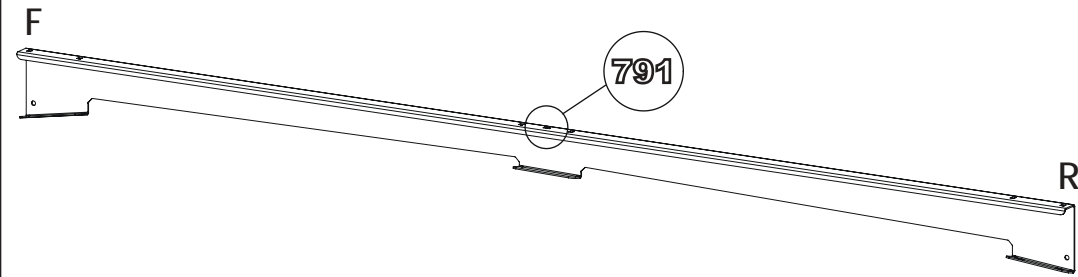

ME0792

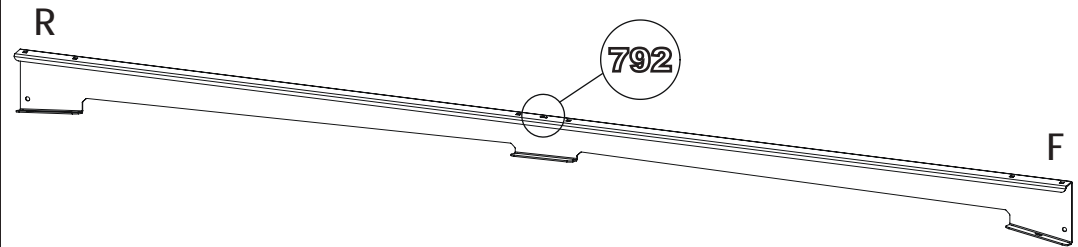

2 Stick rubber pads to the underside of the side rail feet. Please note, the middle foot of the side rail is for support only and is not secured to the vehicle.

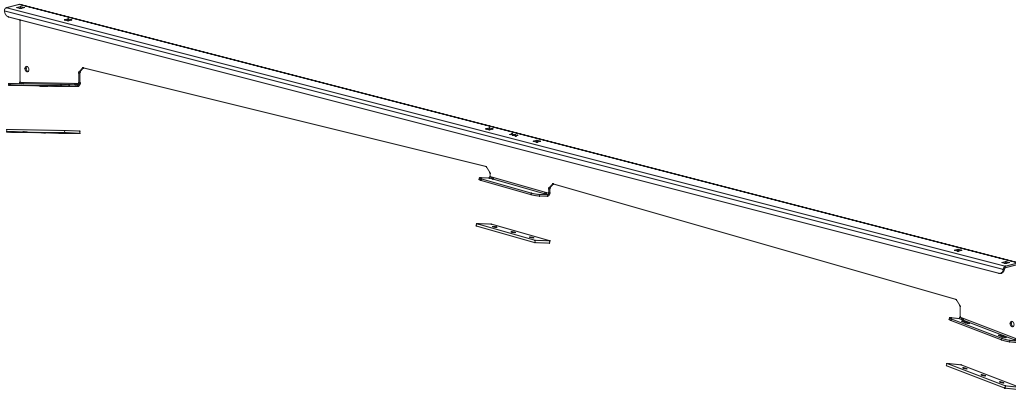

3 Remove roof plugs to reveal the vehicles fixing points. Do not remove the front most roof plug as this is not used to fit this product.

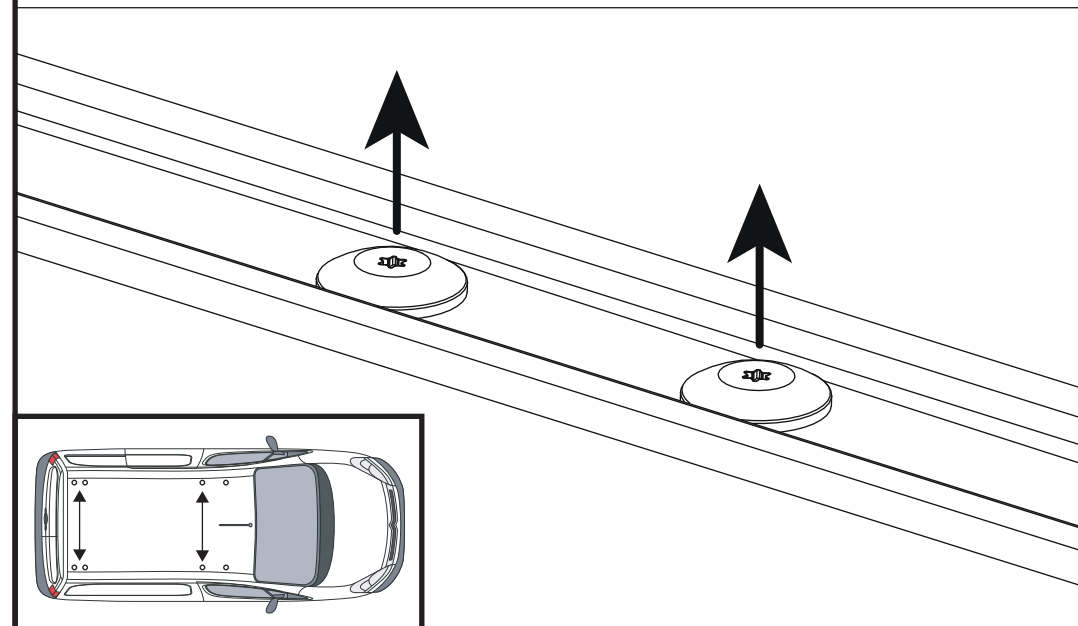

4 Secure the side rails to the vehicles fixing points using M6x25 hex bolts, M6 shakeproofs, M6x20 washers & rubber washers. Ensure that the top hat flange is facing inwards.

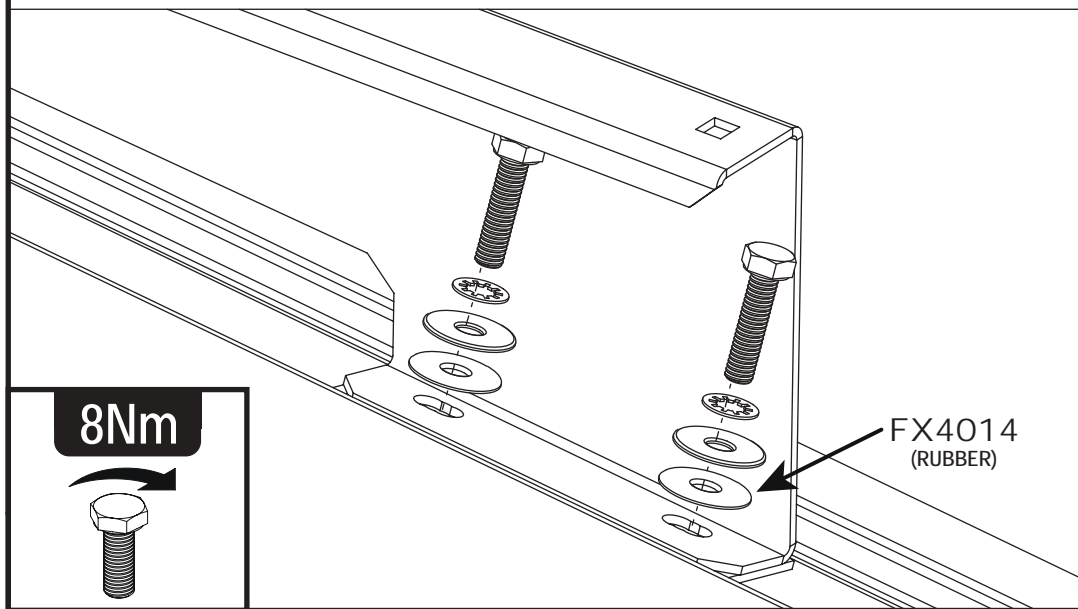

5 Place roof bars onto the side rails with the t-track facing upwards and loosely secure using top hat brackets, M6x16 coach bolts & M6 serrated nuts.

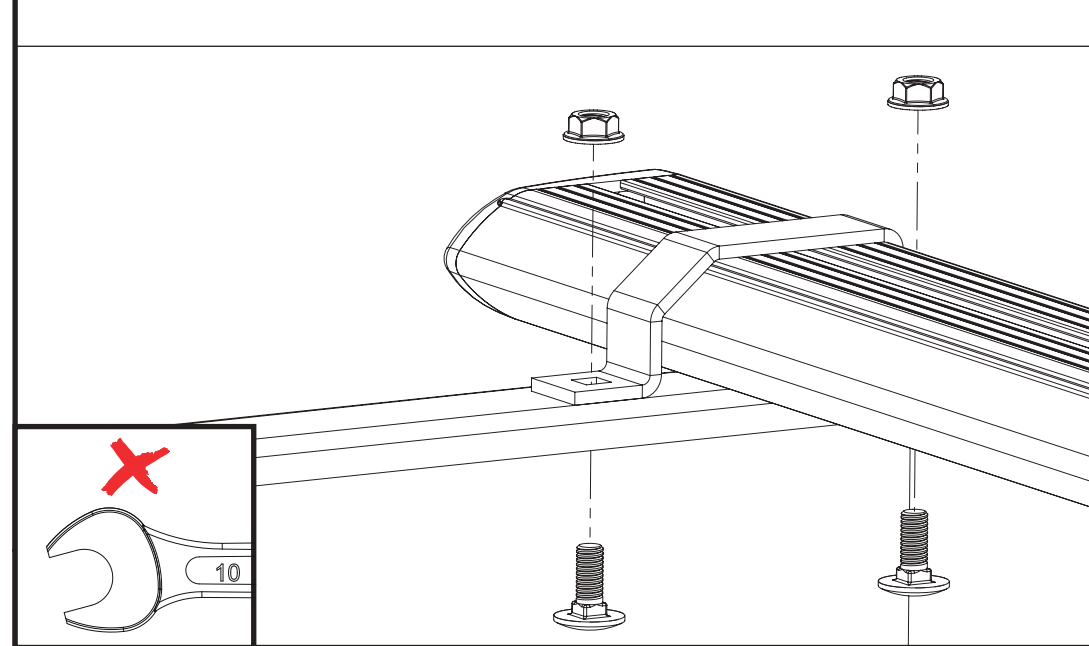

6 Adjust the roof bars to ensure that they are evenly spaced on the vehicle.

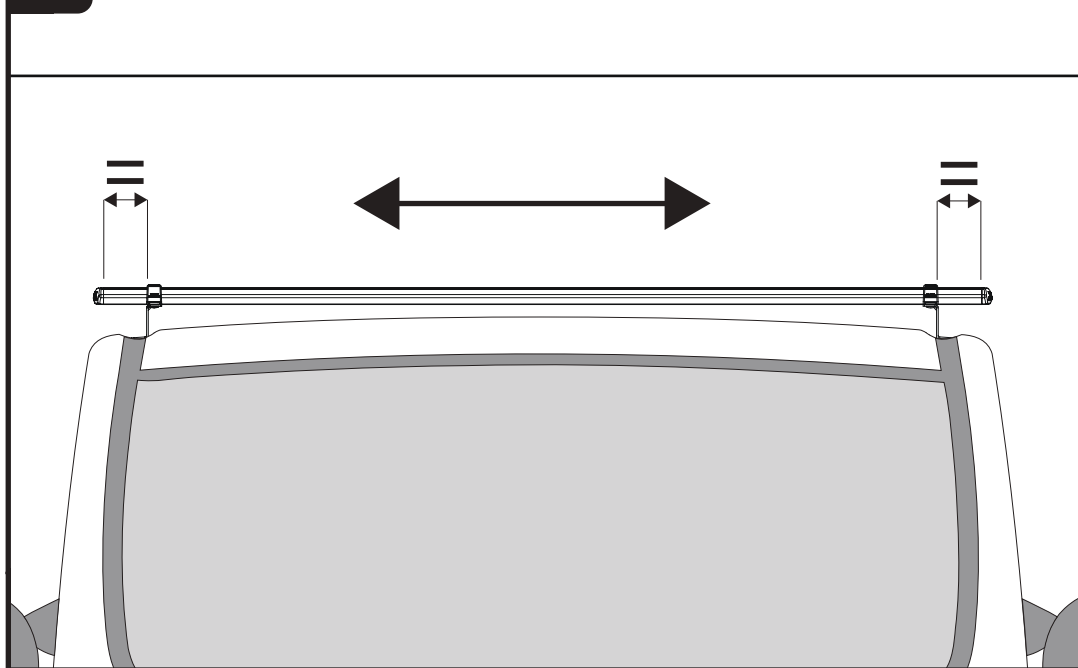

7 Tighten the roof bar fixings to 8Nm.

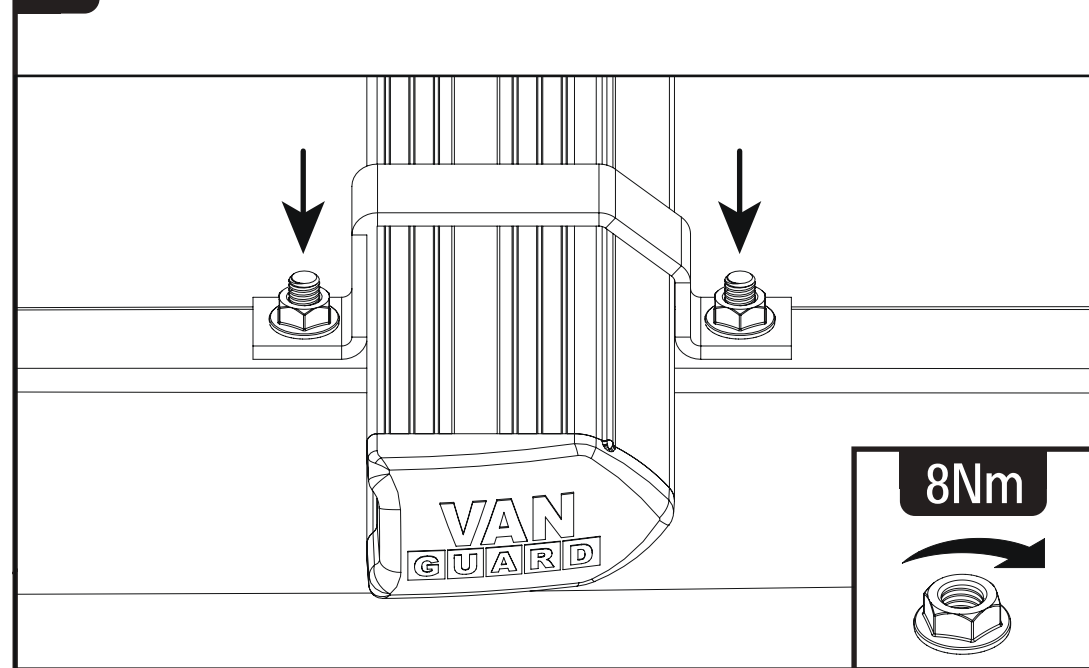

1.

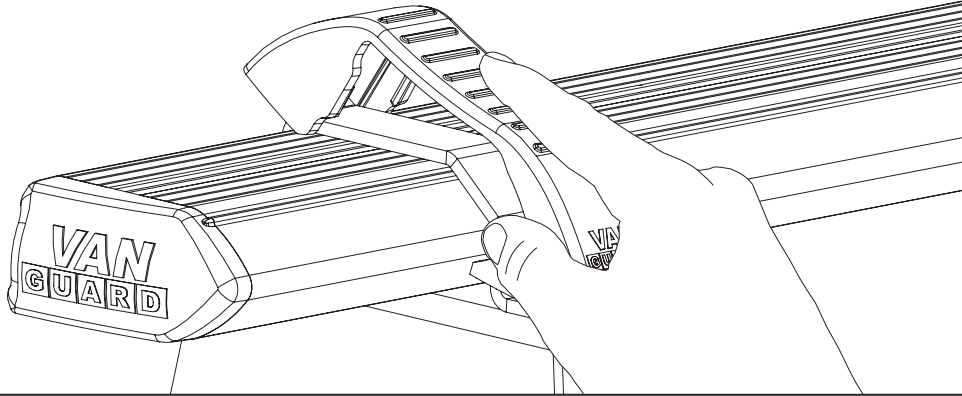

2.

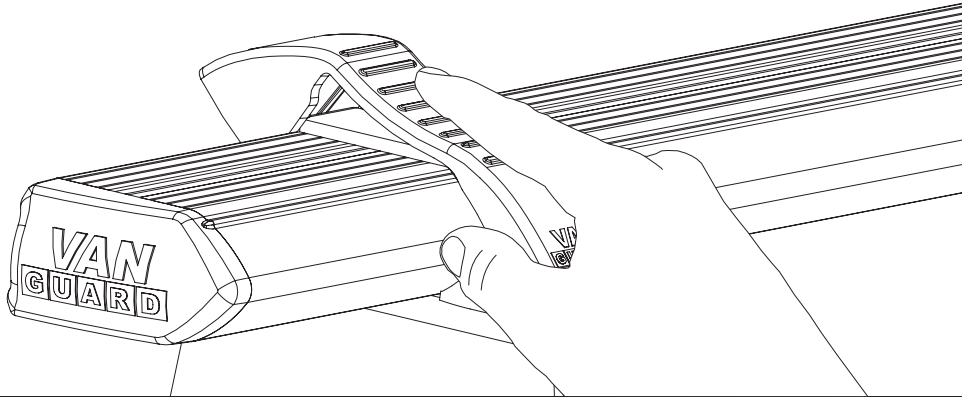

3.

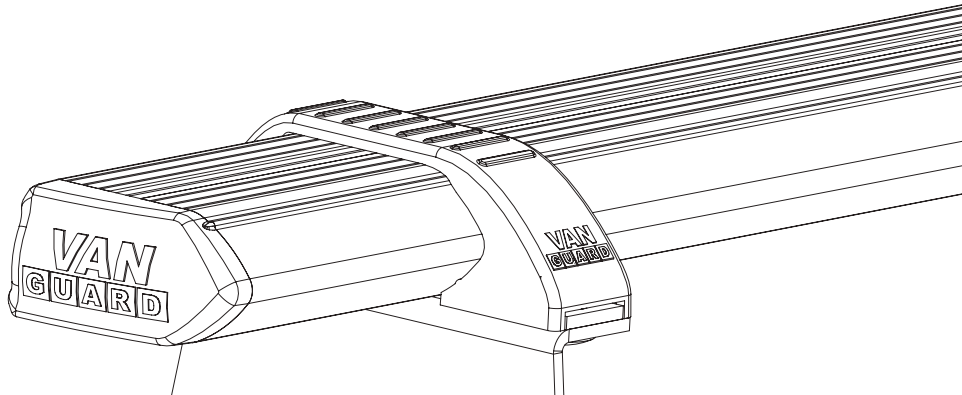

1. Regularly inspect all fixings and parts. Any damaged or worn parts should be immediately removed from the vehicle and replaced.

2. Take care when loading and unloading goods on to and off the vehicles roof.

3. Van Guard Accessories LTD and/ or its distributors do not accept liability for:

- Any products that have been fitted incorrectly.
- Any products which have been fitted to the incorrect vehicle.
- Any products that have been modified in any way or are being used for any purpose that they are unintended for.

4. It is important that the end user receives this document and that instructions are retained for future use.

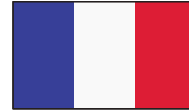

1. Inspecter régulièrement toutes les fixations et les pièces. Les pièces endommagées ou usées doivent être immédiatement retiré du véhicule et remplacé.

2. Prendre garde lors du chargement et du déchargement de marchandises vers et hors des véhicules toit.

3. Van Guard Accessoires Ltd et/ ou ses distributeurs n'accepte pas de responsabilité pour:

- Les produits qui ont été ajustés de manière incorrecte.
- Les produits qui ont été montés sur le véhicule incorrect.
- Les produits qui ont été modifiés de quelque façon ou sont utilisés à toutes fins qu'ils sont involontaires.

4. Il est important que l'utilisateur final reçoit ce document et que les instructions soient conservés pour une utilisation futur.



1. Prüfen Sie regelmäßig alle Befestigungen und Teile. Alle verschlissenen oder beschädigten Teile sollten sofort aus dem Fahrzeug ausgebaut und erneuert.

2. Vorsicht beim Be- und Entladen von Gütern auf und abseits der Fahrzeuge.

3. Van Guard Accessories LTD und/ oder seinen Händlern keine Haftung für:

- Sämtliche Produkte, die falsch montiert worden.
- Alle Produkte, die auf die falsche Fahrzeug.
- Alle Produkte, die nicht in irgendeiner Weise verändert oder verwendet für jeden Zweck, sie sind unbeabsichtigt.

4. Es ist wichtig, dass der Endbenutzer erhält dieses Dokument und die Anweisungen für eine zukünftige Verwendung aufbewahrt werden.



1. Undersøg med jævne mellemrum alle løsdele og fæstninger. Beskadigede eller slidte dele bør straks fjernes fra køretøjet og repareres eller erstattet.

2. Vær meget opmærksom ved lastning og losning af varer fra varevognens tag.

3. VanGuard Accessories Ltd og/eller deres distributører accepterer ikke ansvar for:

- Produkter der ikke er monteret korrekt som angivet i monteringsvejledning.
- Produkter der er blevet monteret på et køretøj, de ikke er beregnede til.
- Produkter der er blevet modificerede på nogen måde eller bliver brugt på en måde, hvortil de ikke er beregnede.

4. Det er vigtigt, at dette dokument overdrages til slutbruger af produktet og at vejledning er gemt til senere brug.