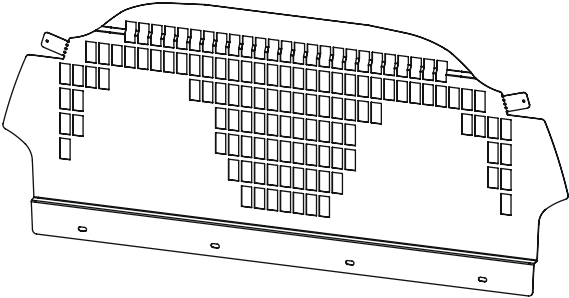
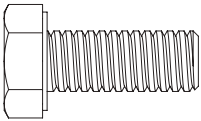
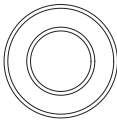
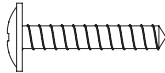
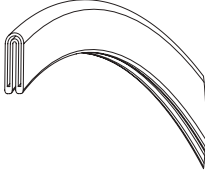

IN8174

Bulkhead - VG251 / VG322

| | | | | |
|--|--|---|---|---|
| <p>VG251S = ME0279 X1 VG251P = ME0280 X1 VG322S = ME0967 X1 VG322P = ME0968 X1 (BULKHEAD)</p>  | <p>FX4018 X4 (M8X20)</p>  | <p>FX4020 X4 (M8)</p>  | <p>FX4091 X2 (No8 X 3/4")</p>  | <p>MA6030 X1 (RUBBER EDGING 1030MM)</p>  |
|--|--|---|---|---|

! CAUTION - IMPORTANT NOTES !

1. You should note that it is the responsibility of the installer/s to ensure that when drilling holes in to your vehicle to take fixings, care must be taken to ensure that the fuel line, tyres, fuel tank, wiring loom, exhaust, bodywork and brake lines etc. are not damaged. Whilst every effort has been made to ensure our products can be safely fitted, changes to vehicles sometimes occur so it's always necessary to check before drilling.

If in doubt refer to the vehicle manufacturer's dealership.

2. When drilling, use as short a drill bit as possible to prevent damage to the vehicle. Use corrosion protection when drilling the vehicle.

3. Wear the appropriate protective equipment (safety glasses & gloves) while fitting this product.

4. Regularly inspect all fixings and parts. Any damaged or worn parts should be immediately removed the vehicle and replaced.

5. Retain instructions for future use. It is important that the end user receives this document.

TOOLS REQUIRED

SPANNER (10MM) X1

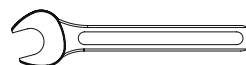

PH SCREW DRIVER X1



DRILL (Ø3.2MM) X1

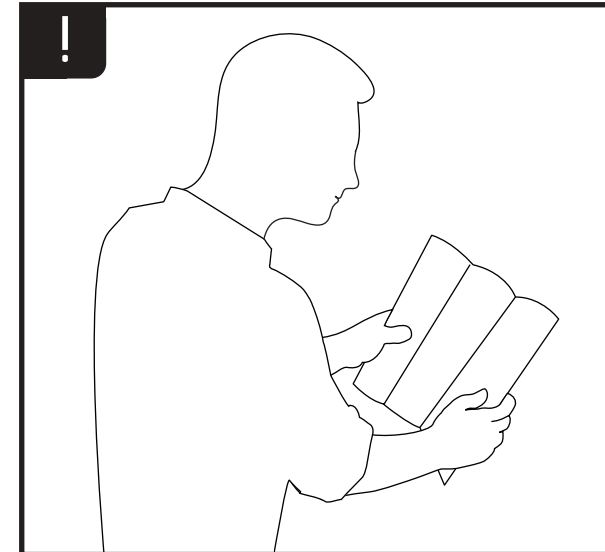
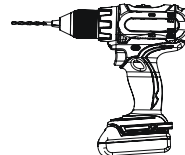

1 Please read the important notes on page 1 before fitting this product. Fit the rubber edging (MA6030) along the top edge of the bulkhead.

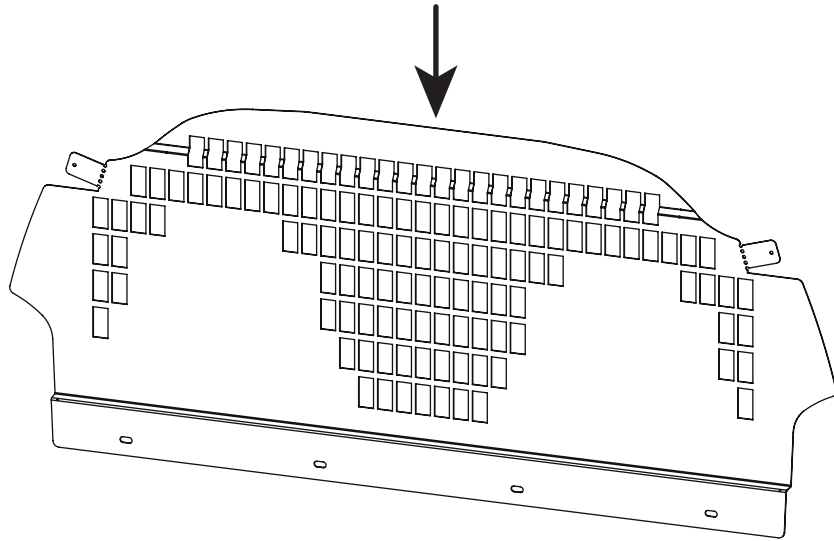

2 Bend the two perforated side tabs up 90 degrees (the same way as the bend in the bulkhead). Take care not to weaken the tabs by bending them the wrong way.

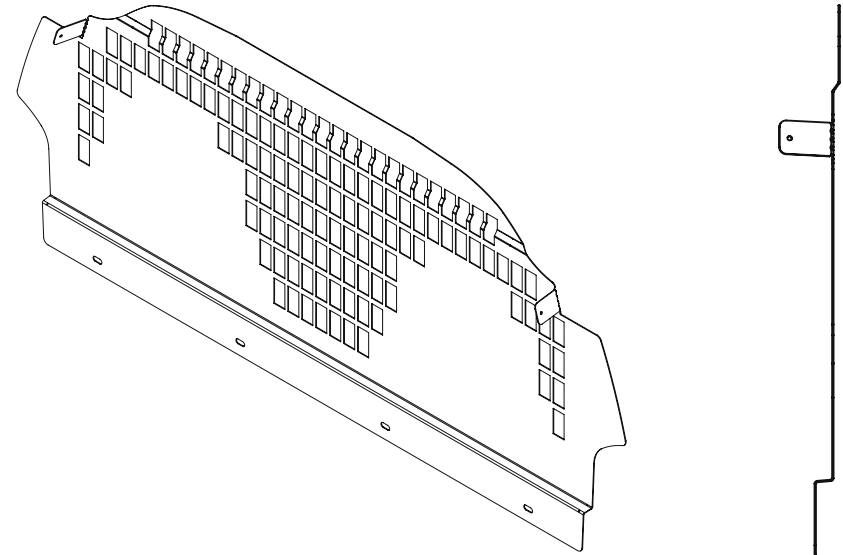

3 Position the bulkhead into the vehicle with the folded returns facing into the cab area and rest on the vehicles existing bottom bulkhead.

Secure the bulkhead to the vehicles existing fixing points along the bottom by bolting from the cab area using M8x20 hex bolts (FX4018) and M8 washers (FX4020).

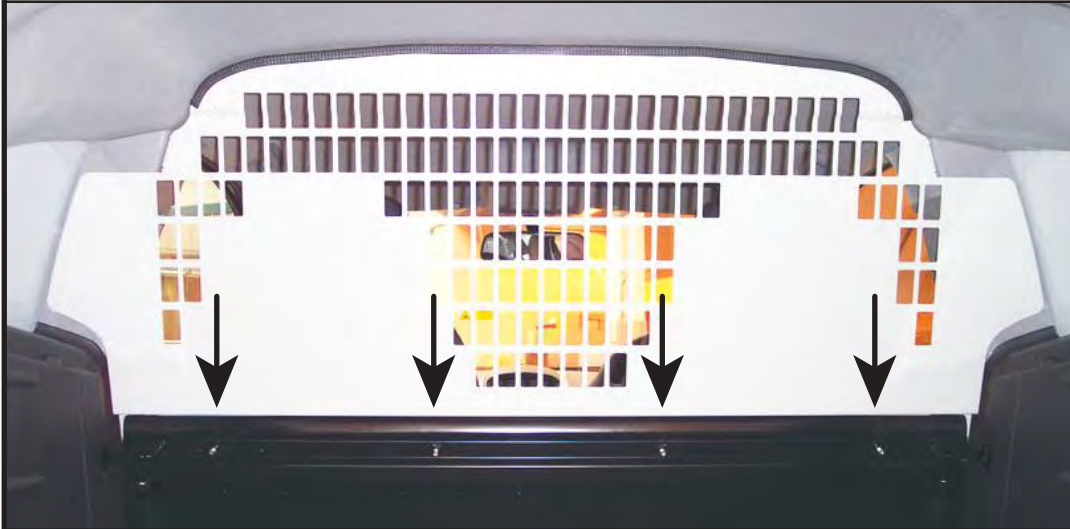

4 Pull the bulkhead forward towards the cab area. Once happy with the position of the bulkhead carefully drill 3.2mm through the tabs and trim and secure in place using No8x3/4" self-tap screws (FX4091).

