

IN8189

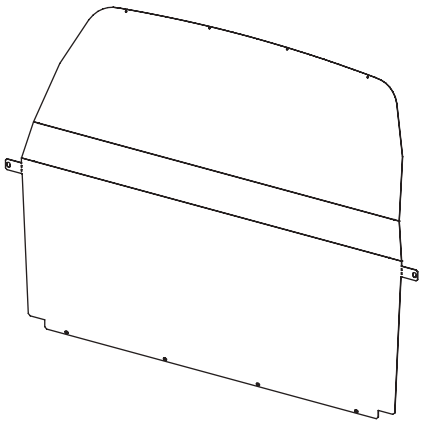
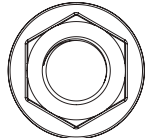
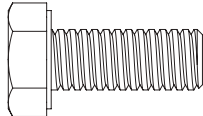
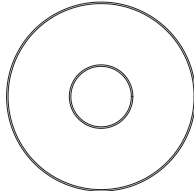
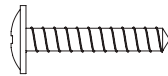

Bulkhead - VG97S / VG97P

| | | | | | |
|--|---|--|--|---|--|
| <p>VG97S = ME0215 X1 VG97P = ME0216 X1</p>  | <p>FX4011 X4 (M8)</p>  | <p>FX4018 X6 (M8X20)</p>  | <p>FX4040 X10 (M8)</p>  | <p>FX4091 X4 (No8 x 3/4")</p>  | |
|--|---|--|--|---|--|

! CAUTION - IMPORTANT NOTES !

1. You should note that it is the responsibility of the installer/s to ensure that when drilling holes in to your vehicle to take fixings, care must be taken to ensure that the fuel line, tyres, fuel tank, wiring loom, exhaust, bodywork and brake lines etc. are not damaged. Whilst every effort has been made to ensure our products can be safely fitted, changes to vehicles sometimes occur so it's always necessary to check before drilling.
If in doubt refer to the vehicle manufacturer's dealership.
2. When drilling, use as short a drill bit as possible to prevent damage to the vehicle. Use corrosion protection when drilling the vehicle.
3. Wear the appropriate protective equipment (safety glasses & gloves) while fitting this product.
4. Regularly inspect all fixings and parts. Any damaged or worn parts should be immediately removed the vehicle and replaced.
5. Retain instructions for future use. It is important that the end user receives this document.

TOOLS REQUIRED

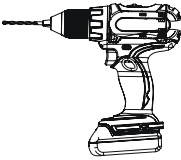
- SPANNER (13MM) X2

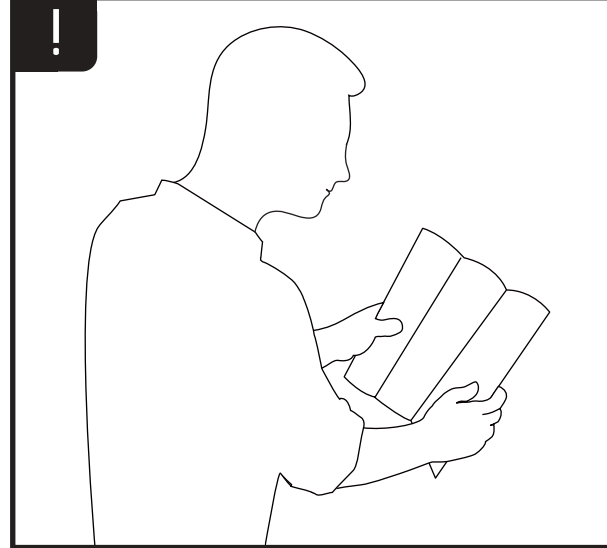
- PH SCREW DRIVER X1

- DRILL (Ø3.2MM) X1

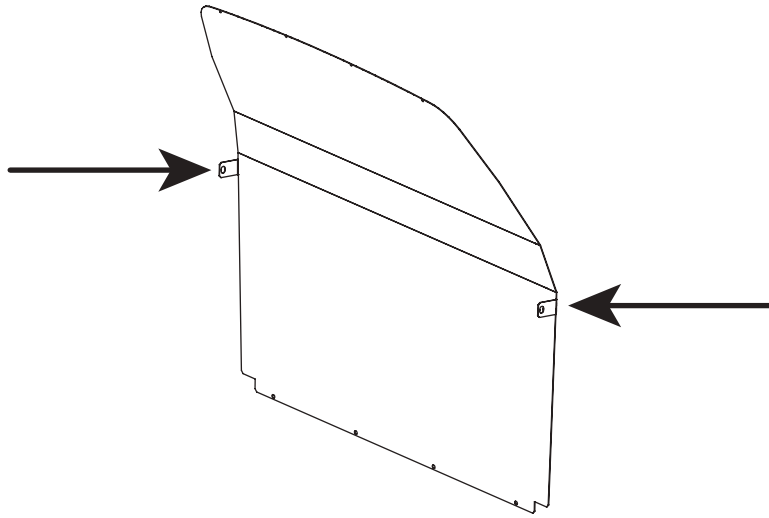

1 Please read the important notes on page 1 before fitting this product. Bend the two tabs along the perforated line. Be careful not to weaken the tabs by bending them the wrong way.

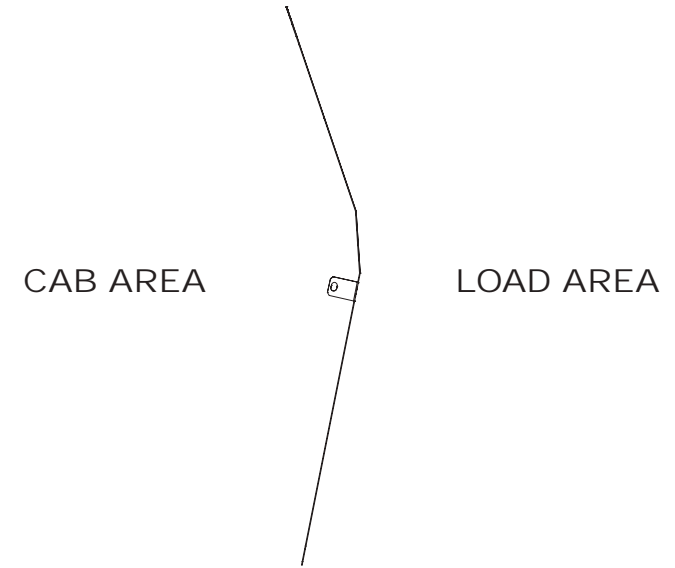

2 Lift the bulkhead into position (two man lift) with the folded tabs facing towards the cab area and rest on the tying hooks.



3 Loosely secure the tabs to the threaded inserts on the door pillars using M8X20 hex bolts and M8 washers.

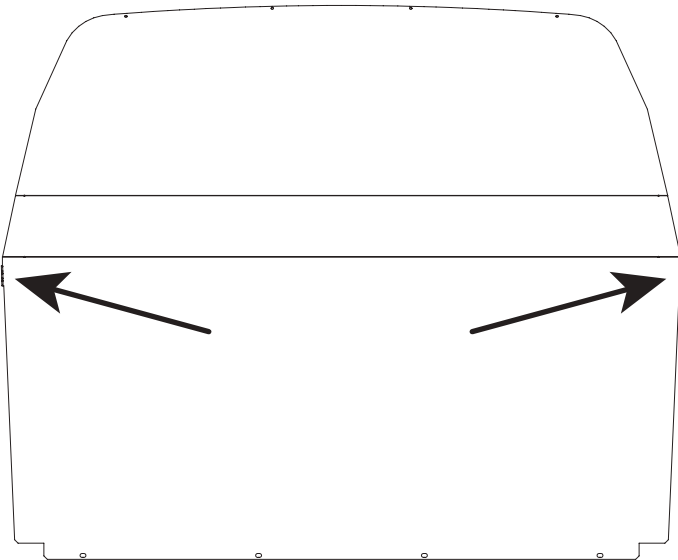

4 Loosely secure the bottom of the bulkhead through the existing holes using M8X20 hex bolts, M8 washers (both sides) and M8 flange nuts.

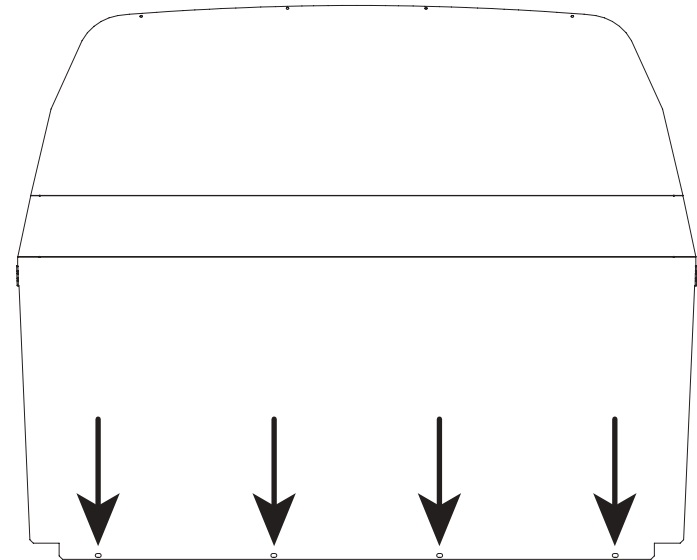

5 Drill 3.2mm through the holes along the top of the bulkhead and secure using No8x3/4" self tap screws (4 fixing positions in total).

Once happy with the position of the bulkhead tighten all fixings.

