

**IN8026**

**ULTI Rack**

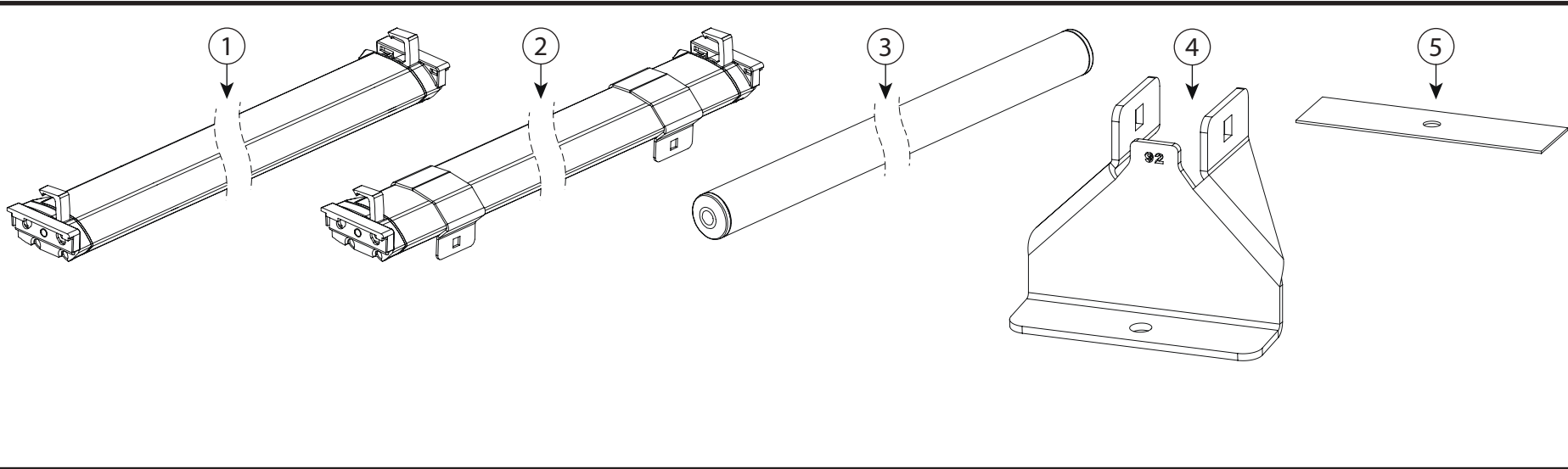

#	PART NO.	QTY
1	AS3005	-
2	AS3006	4
3	AS3160	1
4	ME0092	8
5	MA6018	8

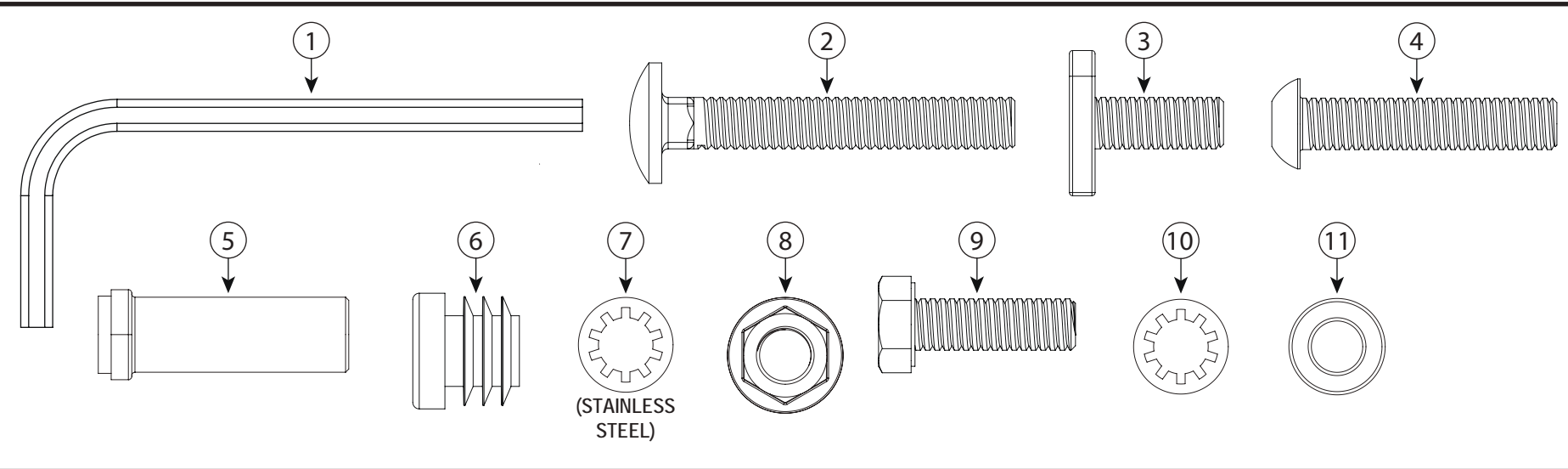

#	PART NO.	QTY
1	FX4008 (M8)	1
2	FX4027 (M8X55)	8
3	FX4139 (M8X20)	2
4	FX4001 (M8X40)	2
5	FX4007	2
6	MA6007	4
7	FX4036 (M8)	2
8	FX4011 (M8)	8
9	FX4028 (M8X25)	8
10	FX4019 (M8)	8
11	FX4020 (M8)	8

This FITTING INSTRUCTION is the property of VAN GUARD ACCESSORIES LTD. and must not be used for manufacturing purposes, copied nor communicated in any way to third parties without written permission from VAN GUARD ACCESSORIES LTD.  
IN8026\_C

Van Guard Accessories Ltd  
Fair Oak Close, Exeter Airport Business Park,  
Exeter, Devon, EX5 2JL  
www.van-guard.co.uk

# VGUR-058

Vehicle:  
Ford Transit: 2014 on  
Wheel Base: LWB (L3)  
Roof Height: Medium (H2)  
Rear Doors: Twin

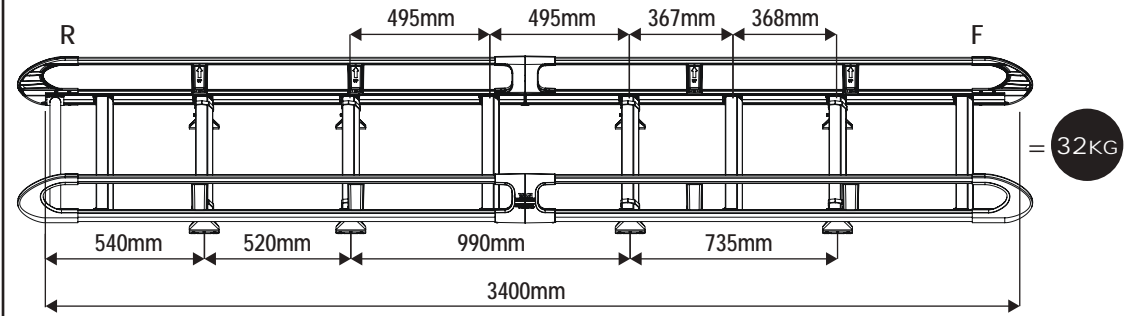
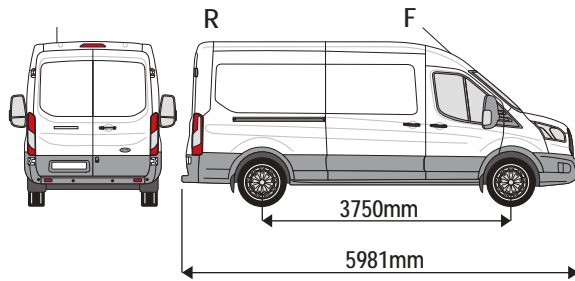

# VGUR-059

Vehicle:  
Ford Transit: 2014 on  
Wheel Base: LWB (L3)  
Roof Height: High (H3)  
Rear Doors: Twin

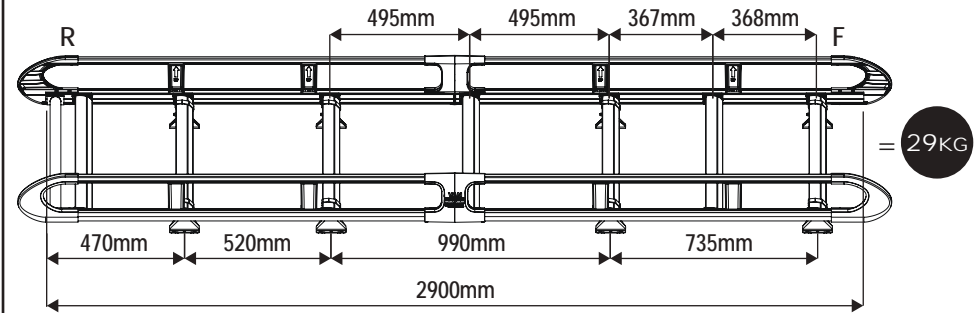
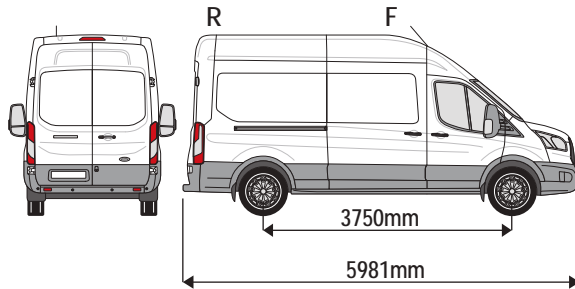

# VGUR-060

Vehicle:  
Ford Transit: 2014 on  
Wheel Base: ELWB (L4)  
Roof Height: High (H3)  
Rear Doors: Twin

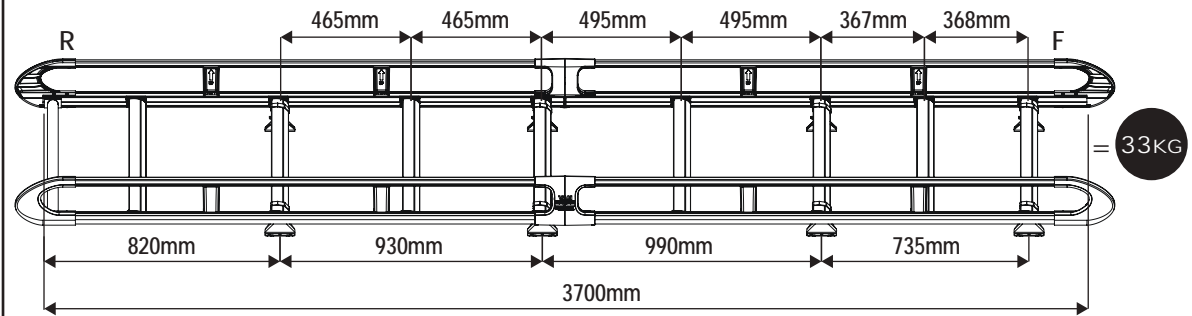
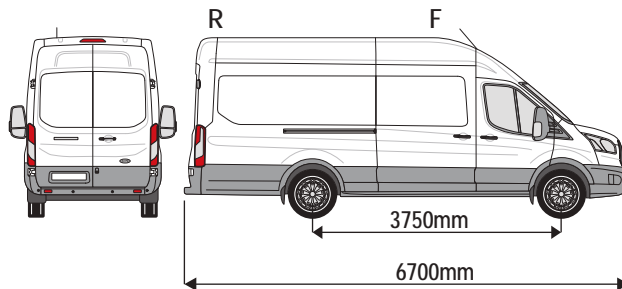

## TOOLS REQUIRED

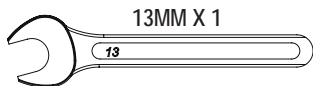

FX4008 (M8) X1  
(SUPPLIED IN FIXING KIT)



ME0182 X1  
(SUPPLIED IN FIXING KIT)

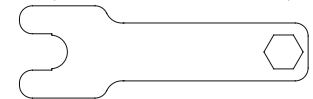

**1** Stick rubber pads to the underside of the roof brackets.

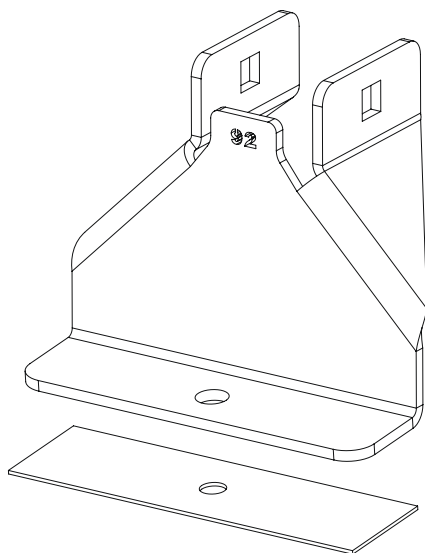

**2** Remove roof plugs to reveal the vehicles fixing points. Secure the roof brackets to the fixing points using M8x25 hex bolts, M8 shakeproof washers and M8 washers.

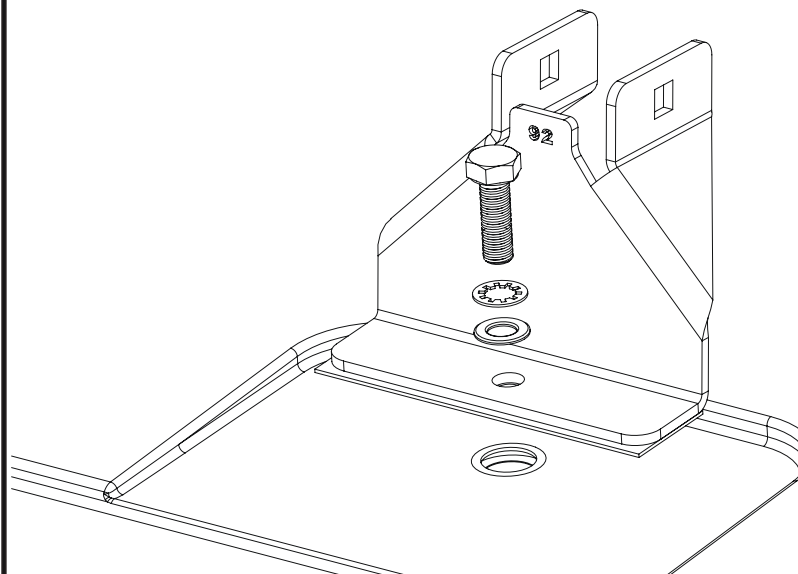

TIGHTEN  
TO  
12Nm

**3** Loosely secure roof bars to the roof brackets using M8x55 coach bolts and M8 flange nuts.

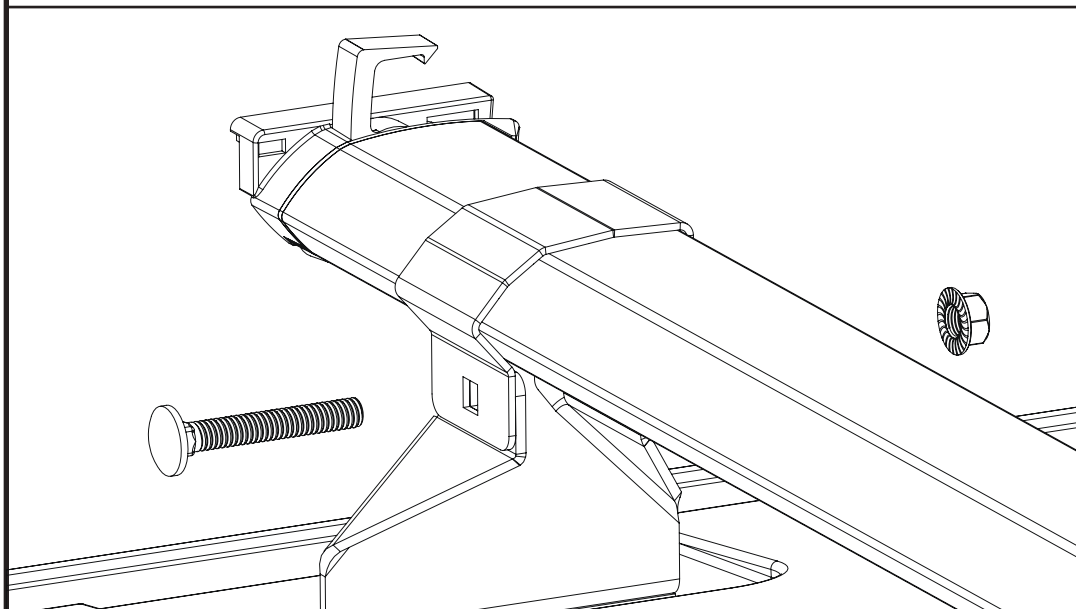

**4** Adjust the roof bars to ensure that they're evenly spaced on the vehicle.

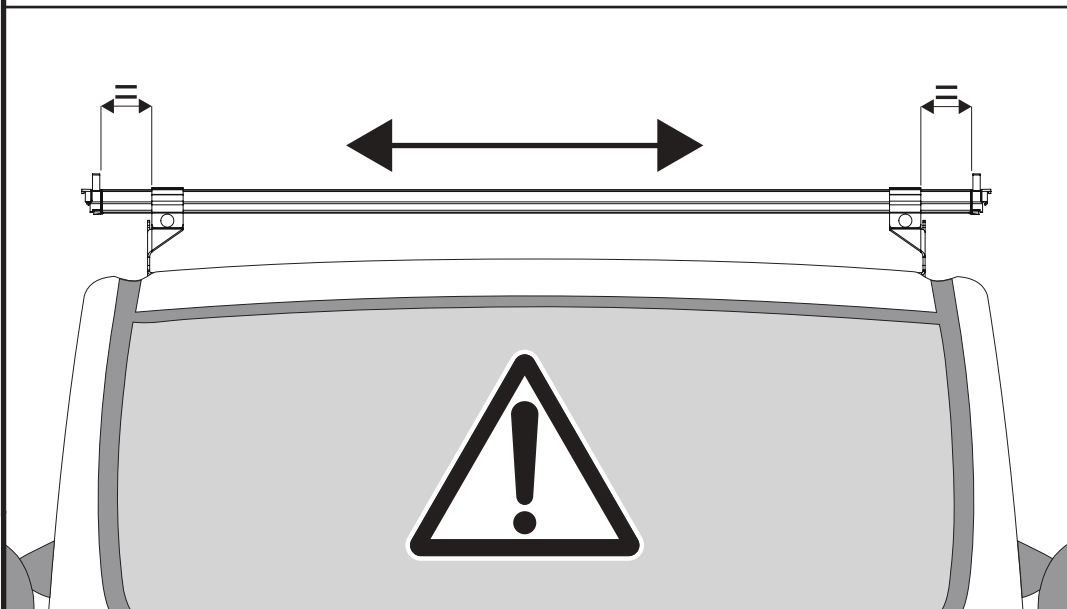

5

Tighten the M8 flange nuts.

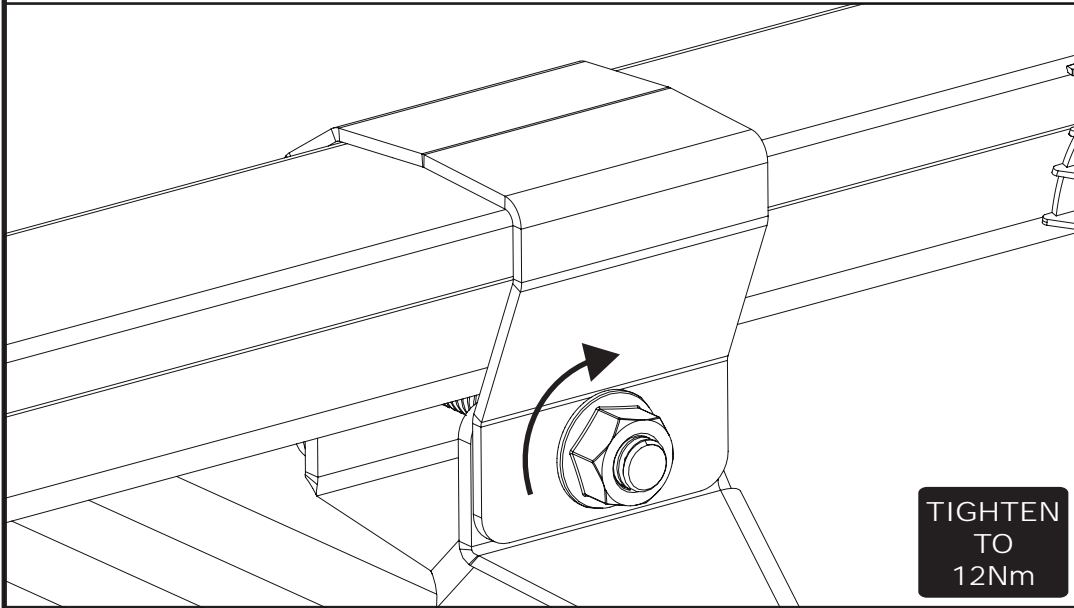

6.1

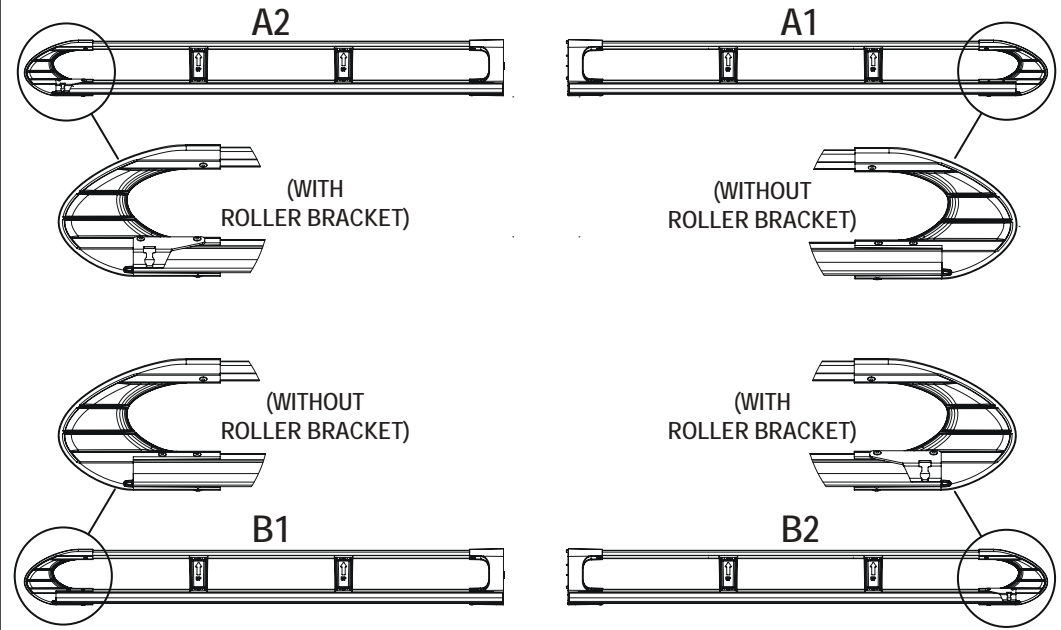

6.2

Lift the rear side rail sections into position (A2 & B2). Ensure that the side rails are connected to the roof bars correctly as per step 6.3.

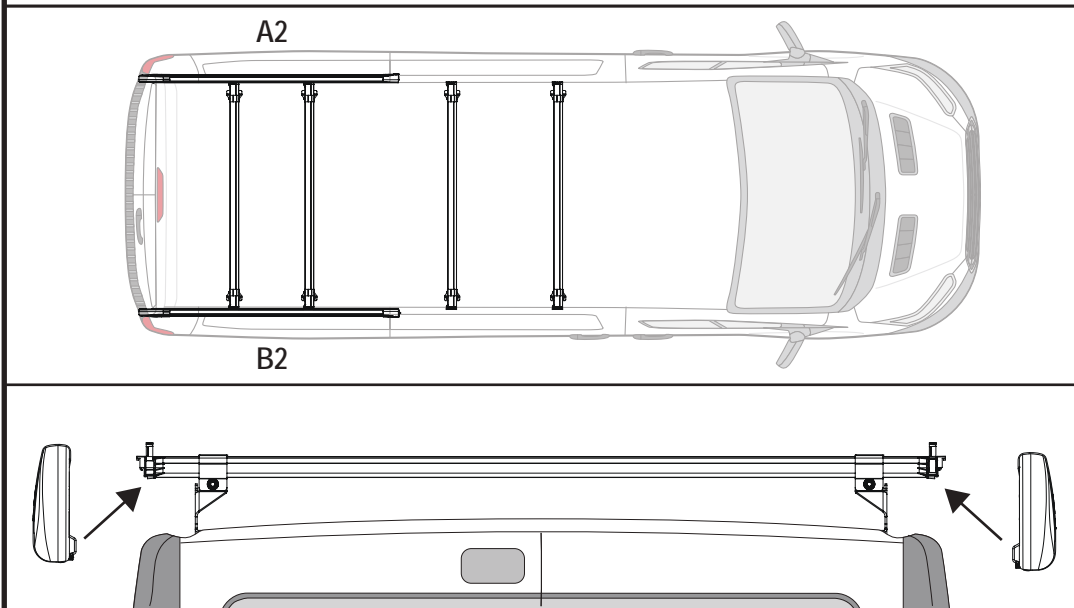

6.3

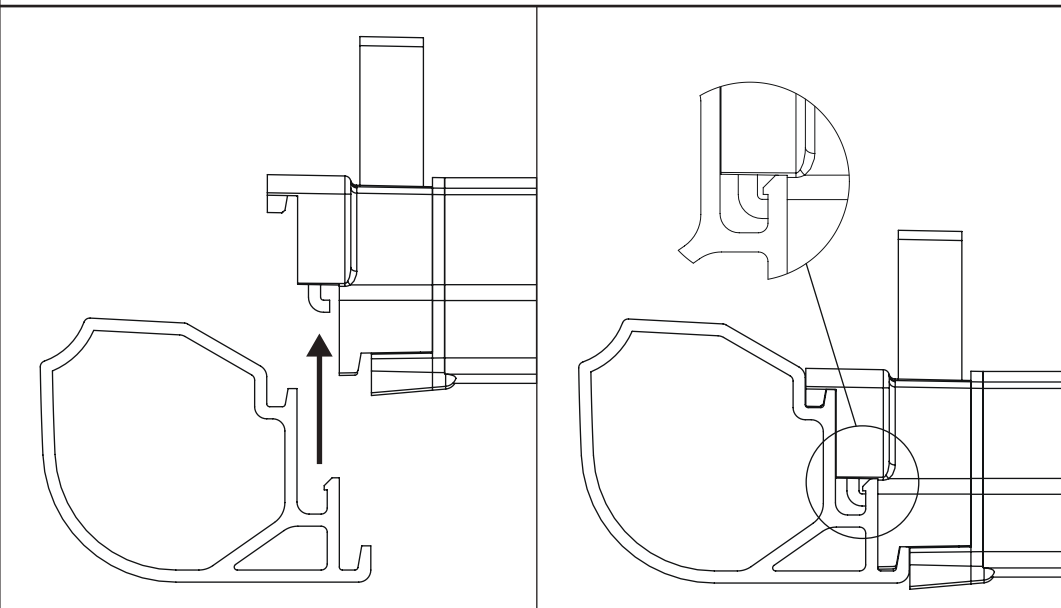

**7** Adjust the position of the rear side rails to suit the rear roller.

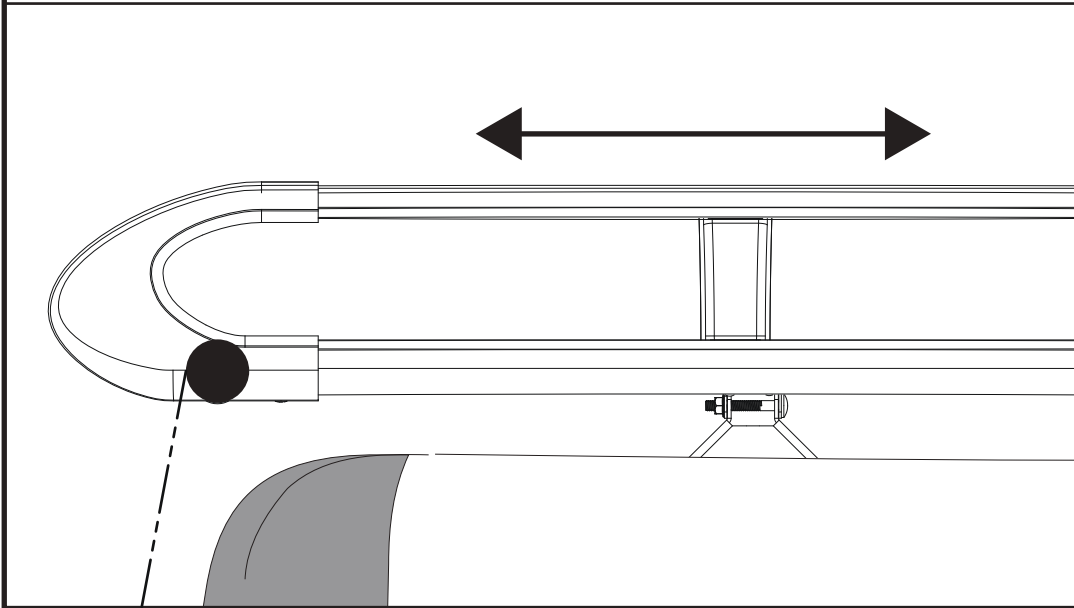

**8** Push on the lever to secure the 2X rear fixed roof bars into position.

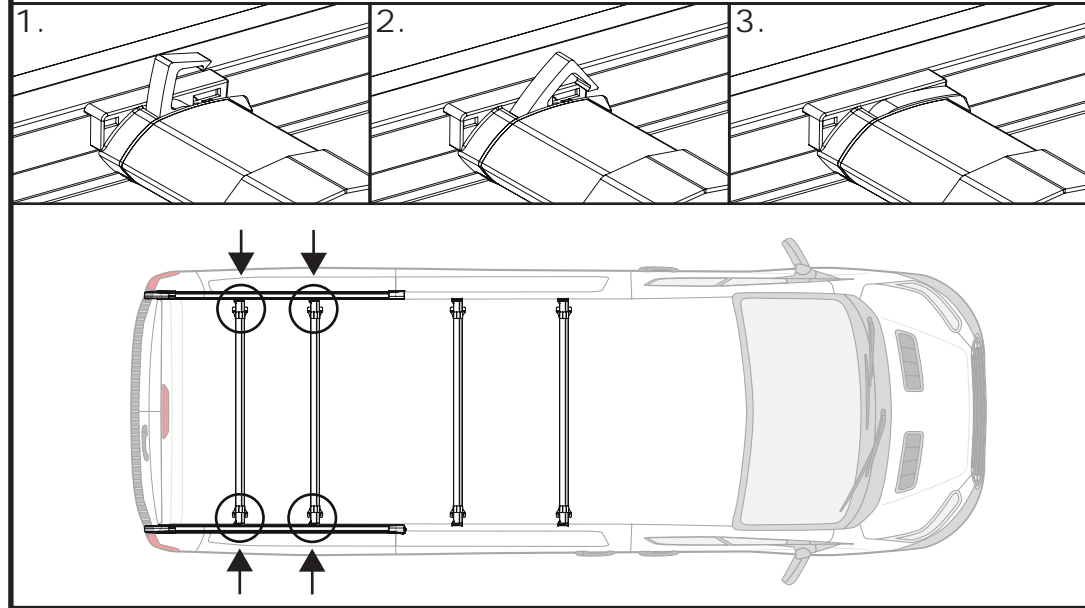

**9** Lift the front side rail sections into position (A1 & B1). Ensure that the side rails are connected to the roof bars correctly as per step 6.3.

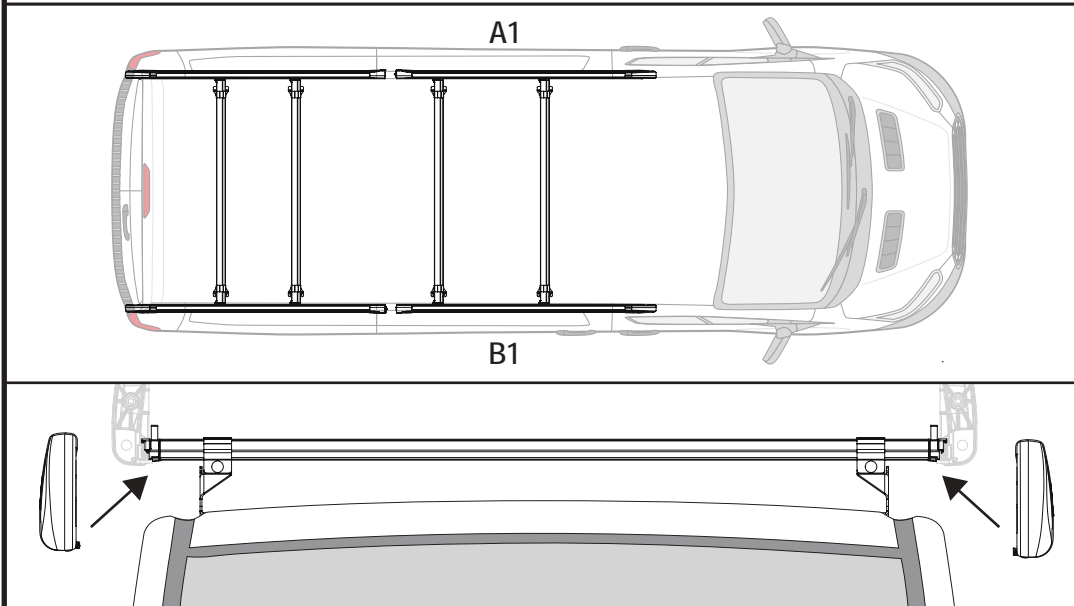

**10** Slide the front side rail up to the rear side rail and secure together using 1X M8x40 button bolt. Tighten using the supplied tool (FX4008). Repeat for the other side.

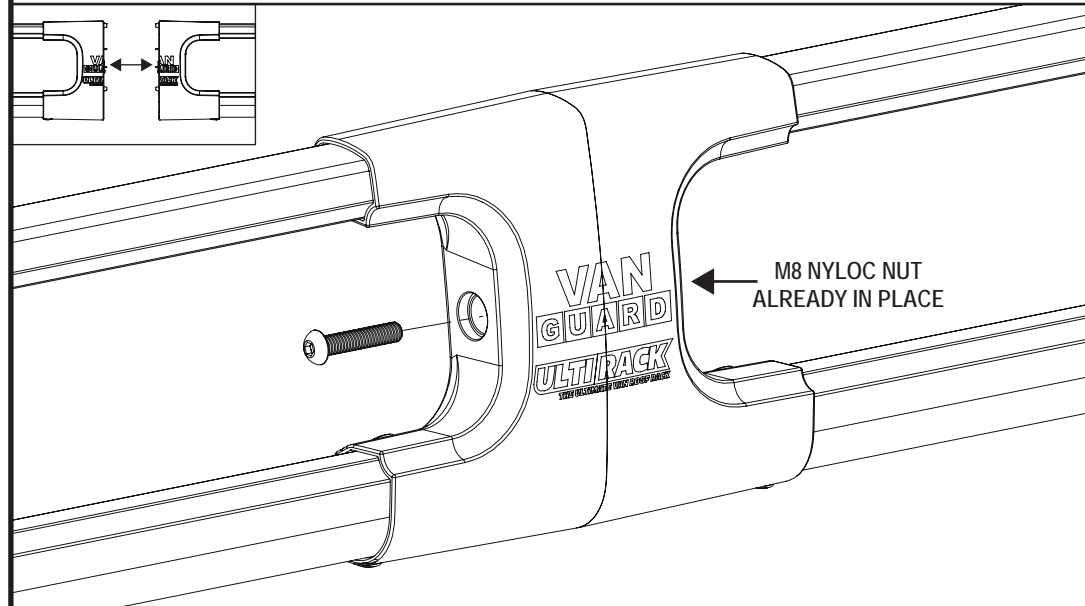

**11** Push on the lever to secure the 2X front fixed roof bars into position.

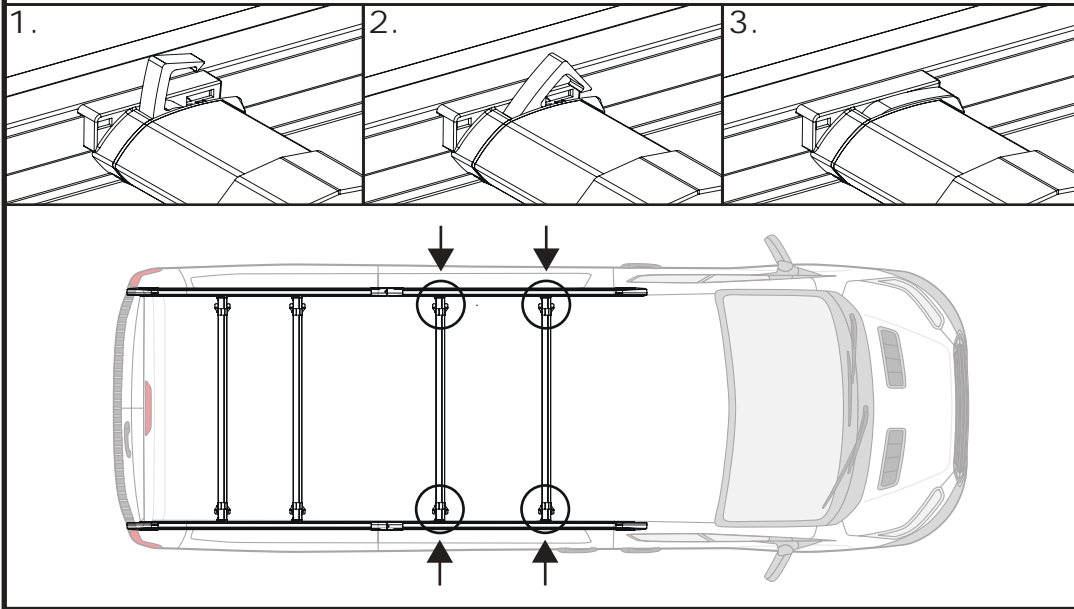

**12** Place the remaining roof bars into position. See page 2 for the recommended distances between the roof bars. Once in position push on the lever to secure in place.

\*IMAGE FOR ILLUSTRATION PURPOSES ONLY

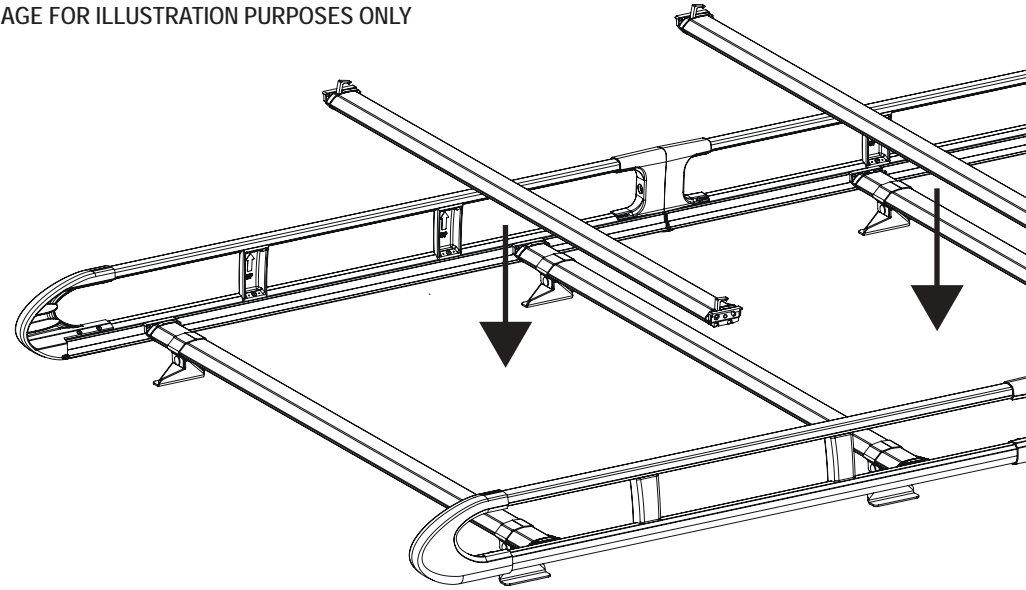

**13** Secure the roller spigot to the left hand roller bracket only using a M8 t bolt (FX4139) and a M8 shakeproof washer. Ensure that the shakeproof is on the inside of the roller bracket and that the spigot sits flush / straight. Tighten using the supplied tool.

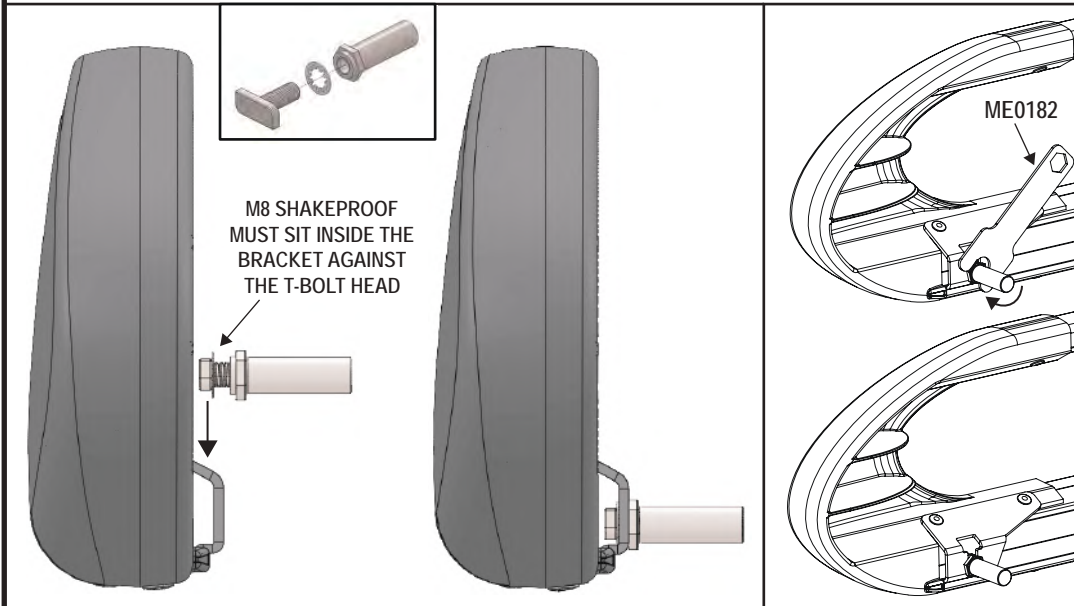

**14** Assemble the roller spigot, M8 t bolt (FX4139) and M8 shakeproof washer together. Place the assembly into the roller. Slide the roller onto the spigot fitted in step 13, drop the other end into position and then tighten using the supplied tool (ME0182).

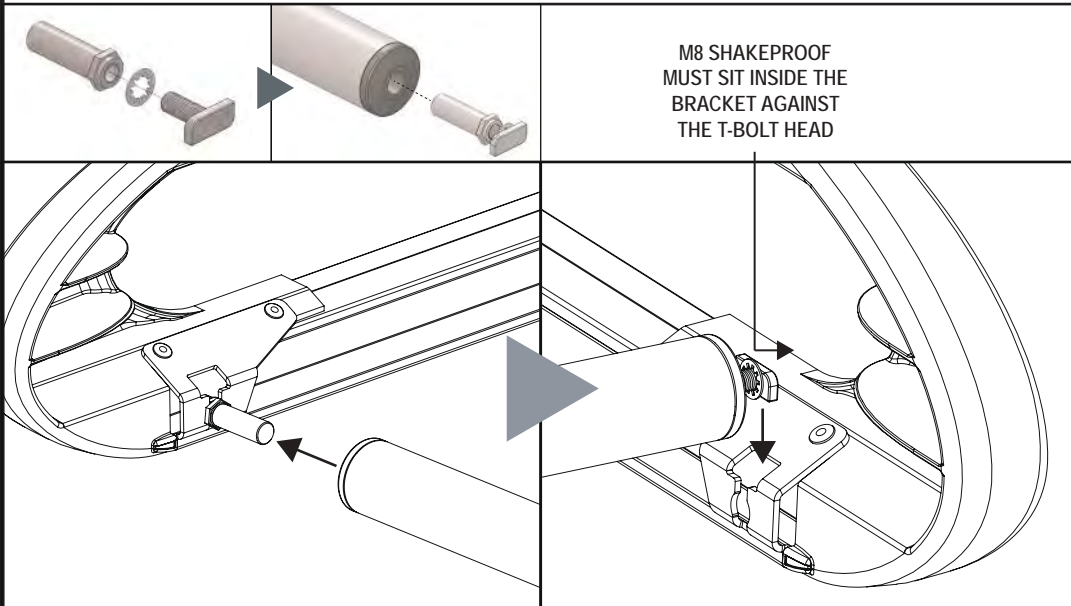

**15** Push the plastic bungs into position (X4).

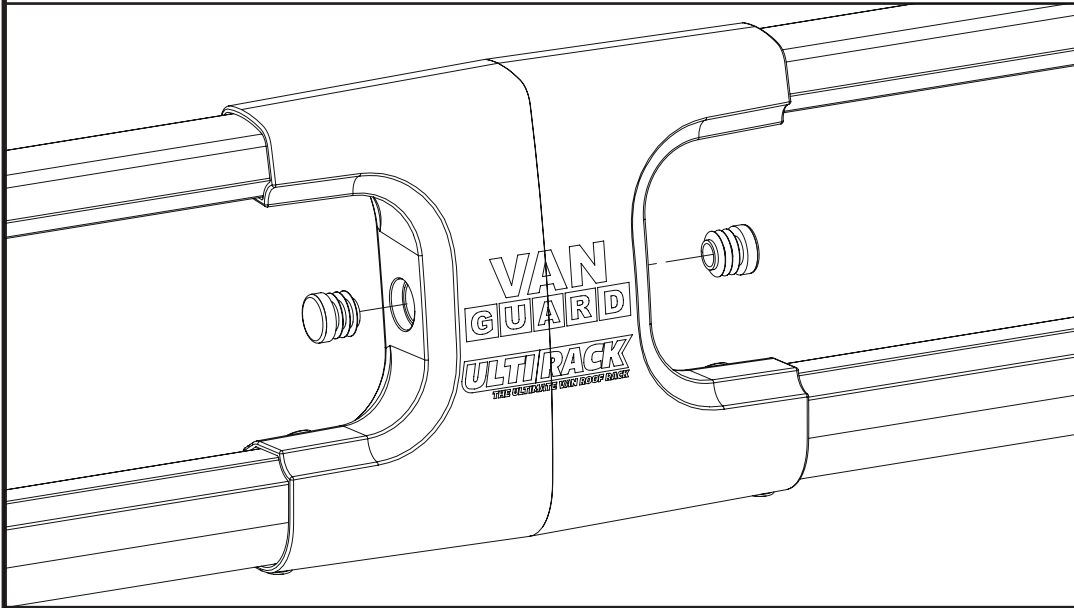

**16** Check bars are fully secured.

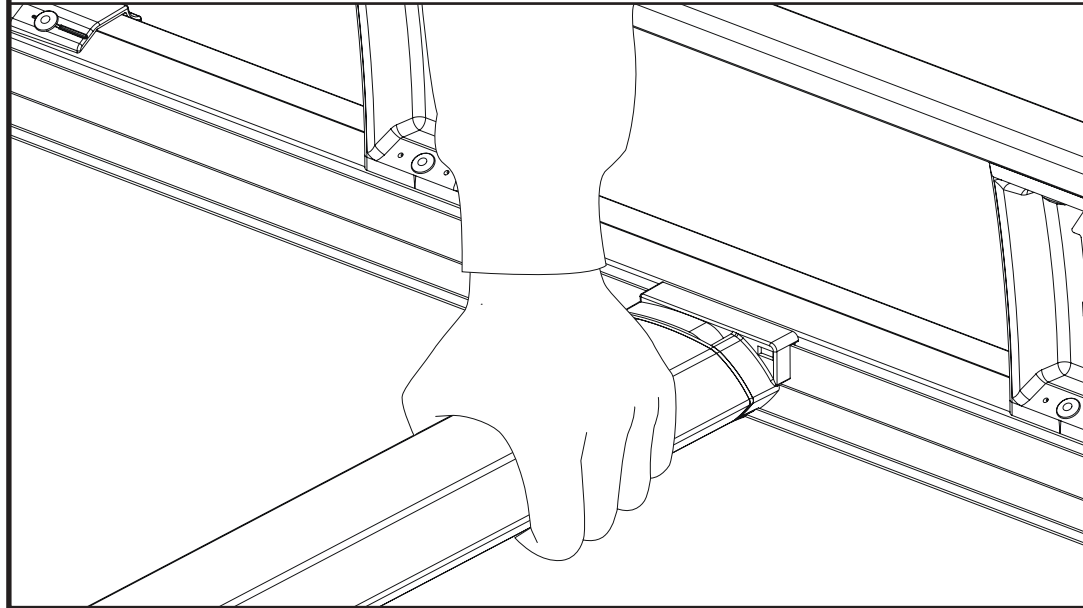

**17** Once the product has been fitted check fixings and parts to ensure they have been fully secured and tightened. Check fixings and parts at regular intervals. Any damaged or worn parts must be immediately removed from the vehicle and replaced.



**NOTES:**

Maximum load capacity: 150KG (Including rack weight - please refer to page 2.) (Maximum load must be in accordance with the vehicle manufacturer's load bearing capacity. Please refer to the vehicles handbook.)

Regularly check all fixings and parts.

Retain these instructions for future reference. It is important that the end user receives this document.